

Electronic Insurance Verification and Interfacility Insurance Update

Integrated Billing Version 2.0

User Guide



**September 2003
Revised: May 2026**

**Department of Veterans Affairs
Office of Information and Technology**

Revision History

NOTE: The revision history cycle begins once changes or enhancements are requested after the document has been baselined.

NOTE: Table 1 includes only the most recent document updates. For brevity, the “Revision History” is truncated to three (3) pages. The complete list of prior revisions is archived in APPENDIX D – Revision History Archive.

Table 1: Abbreviated Revision History

Date	Revision	Description	Author
05/2026	4.6	Updates are for Patch IB*827: <ul style="list-style-type: none"> • Updated actions on several screen shots related to Request Electronic Insurance Inquiry 	VHA HF DSO MCCF eInsurance
02/2026	4.5	Patch IB*822: <ul style="list-style-type: none"> • Added E1 Transactions Enabled’ to the ‘IV Site Parameters’ screen • Added Buffer Symbols for ePharmacy E1 transaction statuses • Updated screen shot related to Request Electronic Insurance Inquiry option • Updated the actions on several screen shots 	VHA HF DSO MCCF eInsurance
08/2025	4.4	Patch IB*2*806: <ul style="list-style-type: none"> • Added the new patient status flag ‘P’ to the ‘Process Insurance Buffer’ screen • Updated ‘eIV Response Report’ and related screens including ‘eIV Ambiguous Policy Report’, ‘eIV Inactive Policy Report’, ‘Patient Insurance Info View/Edit’, and ‘Process Insurance Buffer’ • Added Duplicate Buffer Cleanup to the ‘IV Site Parameters’ screen 	VHA HF DSO MCCF eInsurance

Date	Revision	Description	Author
10/2024	4.3	Patch IB*2*794 <ul style="list-style-type: none"> • Added Fax field to 'Patient Policy' screen • Added Buffer Refresh action to 'Buffer' screens • Added Precert Portal field to 'Insurance Company Editor' and 'Patient Policy Information' screens 	MCCF EDI TAS eInsurance
06/2024	4.2	Patch IB*2*778 <ul style="list-style-type: none"> • Updated 'Type of Policy' column 	MCCF EDI TAS eInsurance
03/2024	4.1	Patch IB*2*771 <ul style="list-style-type: none"> • Added Daily Buffer Rpt Mail Group to table 1 (section 2) and updated related screenshots (section 2.1) 	MCCF EDI TAS eInsurance
12/2023	4.0	Patch IB*2*763 and DG*5.3*1102 <ul style="list-style-type: none"> • Added Insurance Import Enabled (Section 2) • Updated Fix Corrupt Buffers (Section 2.3) • Update screen shots to include Coverage Limitations last updated date and by whom (section 7.1) • Updated Auto Update Report (Section 9.2) • Moved 'User Edit Report' from this document to the "IB*2 Integrated Billing Version 2 User Manual" document, eliminating Section 10. This caused all sections 11 and up to shift by 1, e.g., Section 11 became Section 10, etc. 	MCCF EDI TAS eInsurance
09/2023	3.9	Patch IB*2*752 <ul style="list-style-type: none"> • Removed "Deferred Inquiries" from eIV Statistical Report (sections 9.6 and 9.7) • Removed "List Group Plans without Annual Benefits" report, updated the "User Edit Report" (section 10) • Corrected reference to "eIV Payer Link Report" for two eIV Error Message Descriptions (Appendix B) 	MCCF EDI TAS eInsurance

Date	Revision	Description	Author
02/2023	3.8	Patch IB*2*737 <ul style="list-style-type: none"> • Updated User Edit Report • Removed references to asterisk in the buffer • Added section for Fixed Corrupt Buffers action 	MCCF EDI TAS eInsurance
10/2022	3.7	Updated IB*2*732 and DG*5.3*1080 <ul style="list-style-type: none"> • Update Site Parameters (section 2 and 2.1) • Update Payer Edit (section 3.3) • Update Request a 270 Health Care + Benefits Inquiry (section 6.1) • Update screen shots to include PROSTHETICS and VISION (section 7.1) • Update Appendix B - eIV Error Message Descriptions • Updated references of "eIV Nightly Process" to be "eInsurance Night Process". The software was changed with IB*2.0*687, but we missed this in the documentation. 	MCCF EDI TAS eInsurance

Table of Contents

1	Introduction	1
1.1	Electronic Insurance Verification (eIV) Process Flow	1
1.2	Intended Audience	2
1.3	Role of the Insurance Verification Interface	2
1.4	National Insurance Payers	3
2	Site Parameters	4
2.1	Define General Parameters	10
2.2	Define Batch Extract Parameters	13
2.3	Fix or List Corrupt Buffers	13
2.4	Duplicate Buffer Cleanup	14
3	Payers	14
3.1	Link Insurance Company to Payers using Link Insurance Company to Payers	15
3.2	Link Insurance Company to Payers using Insurance Company Editor	17
3.3	Payer Edit	19
4	Process Insurance Buffer	21
4.1	Status Flags	21
4.1.1	Buffer Symbols	21
4.1.2	Buffer Entry Status Flags	22
4.1.3	Patient Status Flags	22
4.1.4	Buffer Entry Source of Information Indicators	23
4.1.5	Insurance Entry Update Methods	24
4.2	Buffer Actions	24
4.2.1	Process Entry	25
4.2.2	Reject Entry	36
4.2.3	Expand Entry	37
4.2.4	Add Entry	39
4.2.5	Sort Buffer Views	41
4.2.6	Check Insurance Company	42
4.2.7	Buffer Views: Complete, Positive, Negative, Medicare, Failure, ePharmacy	43
4.2.8	AAA Errors – Complete Buffer View, Expand Entry	43
5	Medicare Potential Insurance Worklist – Potential COB Report	45
5.1	User Prompts	45
5.1.1	Search Criteria – Potential COB Worklist	46

5.1.2	Sort Criteria – Potential COB Worklist.....	46
5.1.3	Format – Potential COB Worklist.....	46
5.1.4	Screen ListManager for Completed Entries – Potential COB Worklist.....	46
5.1.5	ListManager – Potential COB Worklist.....	46
5.1.6	Comments – Potential COB Worklist.....	47
5.1.7	Visual Indicators – Potential COB Worklist.....	47
6	Request Electronic Insurance Inquiry	47
6.1	Request a 270 Health Care + Benefits Inquiry	47
6.2	Request an Electronic Insurance Coverage Discovery Inquiry	49
7	Patient Insurance Info View / Edit	50
7.1	View Patient Policy Information.....	51
7.1.1	Patient Policy Comments	54
7.2	View Eligibility Benefit Information.....	56
8	IIV Auto Match Payers.....	59
8.1	Auto Match in VistA Applications.....	59
8.2	Types of Auto Match Matches.....	60
8.2.1	Simple Auto Matches.....	60
8.2.2	Wildcard Auto Match Matches	60
8.3	Enter / Edit Auto Match Entries (AE).....	60
8.3.1	Add an Auto Match Entry.....	60
8.3.2	Edit an Auto Match Entry	61
8.3.3	Delete an Auto Match Entry.....	62
8.4	Add Auto Match Entries Using Insurance Buffer Data	63
8.5	Check Insurance Buffer Company Names.....	64
8.6	Change Company Name via the Insurance Buffer.....	65
9	eIV Reports	70
9.1	HL7 Response Report.....	71
9.2	eIV Auto Update Report.....	72
9.3	eIV Response Report	74
9.4	eIV Payer Report.....	77
9.5	Medicare Potential Insurance Worklist - Potential COB Worklist / Report.....	79
9.5.1	Medicare Potential COB – as a Worklist.....	80
9.5.2	Medicare Potential COB – as a Report.....	82
9.6	eIV Statistical Report	83
9.7	MailMan Summaries.....	85

9.8	MailMan Notification to Link Payers	86
9.9	MailMan Notification to Activate Payers	87
9.10	eIV Ambiguous Policy Report	87
9.11	eIV Inactive Policy Report.....	89
10	Exporting Reports to Excel	90
11	Schedule / Unschedule MailMan Messages	92
12	Real Time Insurance Verification Inquiry	93
13	Purging eIV Files (IRM Users)	95
13.1	Purge Transmission Queue and or Response File.....	95
13.2	Purge Mailman Reminder.....	96
14	Appendix A – eIV Troubleshooting.....	97
14.1	No eIV Inquiries Transmitted	97
14.1.1	Site Parameters.....	97
14.1.2	Restoring Connectivity to FSC (IRM).....	97
14.1.3	Requeue Batch Process (IRM).....	98
14.1.4	Restart HL7 Logical Link (IRM).....	98
14.2	No link between an Insurance Company and a Payer.....	98
14.3	A Buffer or Appointment Extract Entry Failed to Create an Inquiry.....	98
15	Appendix B – eIV Error Message Descriptions.....	100
16	Appendix C – Acronyms / Abbreviations / Terms	104
17	APPENDIX D – Revision History Archive	106

List of Figures

Figure 1: eIV Process Flow	2
Figure 2: Flowchart of eIV Processes	3
Figure 3: Flowchart of Inquiries from VistA to Payers and Responses from Payers to VistA	4
Figure 4: Open Dialog Box.....	91
Figure 5: Opened File.....	92

List of Tables

Table 1: Abbreviated Revision History	ii
Table 2: IV Site Parameters – General (Editable)	4
Table 3: IV Site Parameters – eIV Parameters (Non-editable).....	5
Table 4: IV Site Parameters – Buffer Cleanup	7
Table 5: IV Site Parameters – Batch Extracts: Buffer Extract.....	7

Table 6: IV Site Parameters – Batch Extracts: Appointment Extract	7
Table 7: IV Site Parameters – Batch Extracts: Non-verified Extract.....	8
Table 8: IV Site Parameters – Batch Extracts: EICD Extract	8
Table 9: IV Site Parameters – IIU (non-editable)	9
Table 10: Buffer Symbols.....	21
Table 11: Patient Status Flags.....	22
Table 12: Buffer Entry Source of Information Indicators.....	23
Table 13: Insurance Entry Update Methods.....	24
Table 14: Acronyms / Abbreviations / Terms	104
Table 15: Revision History Archive.....	106

1 Introduction

In 1996, Congress passed into law the Health Insurance Portability and Accountability Act (HIPAA). This Act directs the federal government to adopt national electronic standards for automated transfer of certain health care data between health care payers, plans, and providers. Now that these standards are in place, the Veterans Health Administration (VHA) will submit electronic 270 Health Care Benefits Eligibility Inquiries to payers and receive 271 Health Care Benefits Eligibility Responses from the payers.

1.1 Electronic Insurance Verification (eIV) Process Flow

The VistA (Veterans Health Information Systems and Technology Architecture) users enter patient insurance information through a variety of processes:

- Insurance information may be entered manually during the Registration process
- It may be entered when the patient's insurance card is read by the insurance card reader
- A user may enter patient's insurance information directly into the Patient file using the Patient Insurance Info View/Edit option

Regardless of how the patient's insurance information gets entered into VistA, it must be verified with the insurance company and the verification must be periodically updated. The goal of the eIV process is to automate as much of the verification process as possible to ensure that the insurance information, used to submit claims for services rendered to the patient, is accurate and up to date. This in turn, increases the likelihood of timely reimbursement and increased revenue.

The eIV interface is bi-directional. The HIPAA Health Care Eligibility Benefit Inquiry transaction is referred to as the 270 and the Response is referred to as the 271. The 270 Health Care Eligibility Benefit Inquiry originates at a VAMC VistA system and is transmitted as a Health Level Seven (HL7) message to the Eligibility Communicator at the Financial Services Center (FSC) in Austin, TX. At FSC, the HL7 message is translated into a HIPAA compliant 270 Health Care Eligibility Benefit Inquiry message and sent to one of the VA's clearinghouses. From the clearinghouse, the 270 message is transmitted to the designated payer.

The 271 Health Care Eligibility Benefit Response originates at the payer and is sent to FSC through the clearinghouse. FSC translates the response back into an HL7 message and transmits it to the originating VAMC VistA system.

Figure 1: eIV Process Flow

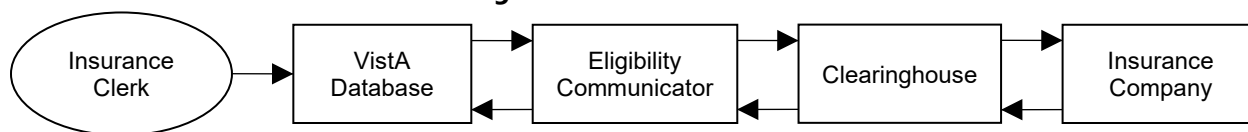

1.2 Intended Audience

The information in this guide is primarily intended for those users who create, update, accept and reject insurance buffer entries or otherwise maintain patients' insurance data using VistA Integrated Billing (IB) software.

1.3 Role of the Insurance Verification Interface

The goal of the electronic insurance verification software is to replace much of the telephone work performed by insurance personnel to verify patients' health care insurance.

Electronic insurance inquiries can be made to any electronically active payer.

Automating the insurance verification process should result in an increase in the accuracy and timeliness of patient insurance information in VistA. These improvements will, in turn, reduce the number of rejected third-party claims for services rendered to the Veteran by the Veteran's Administration (VA).

VistA performs both a Buffer Extract and an Appointment Extract. For the Appointment Extract, VistA prepares HL7 inquiries during the night in response to appointment events. For the Buffer Extract, VistA immediately prepares HL7 inquiries in response to registration and check in events. The HL7 inquiries are transmitted to the Eligibility Communicator at the FSC. The messages are translated into 270 Health Care Eligibility Benefits Inquiry messages. They are then sent to the VA's clearinghouses who then distribute them to the correct insurance companies. The 271 Health Care Eligibility Benefits Responses are returned from the payer through the clearinghouses to FSC for translation into an HL7 format and then transmitted to the originating VistA system. There the information is either placed into the insurance buffer for the insurance clerk to review and process to the patient's insurance file or used to automatically update the patient's insurance file.

Figure 2: Flowchart of eIV Processes

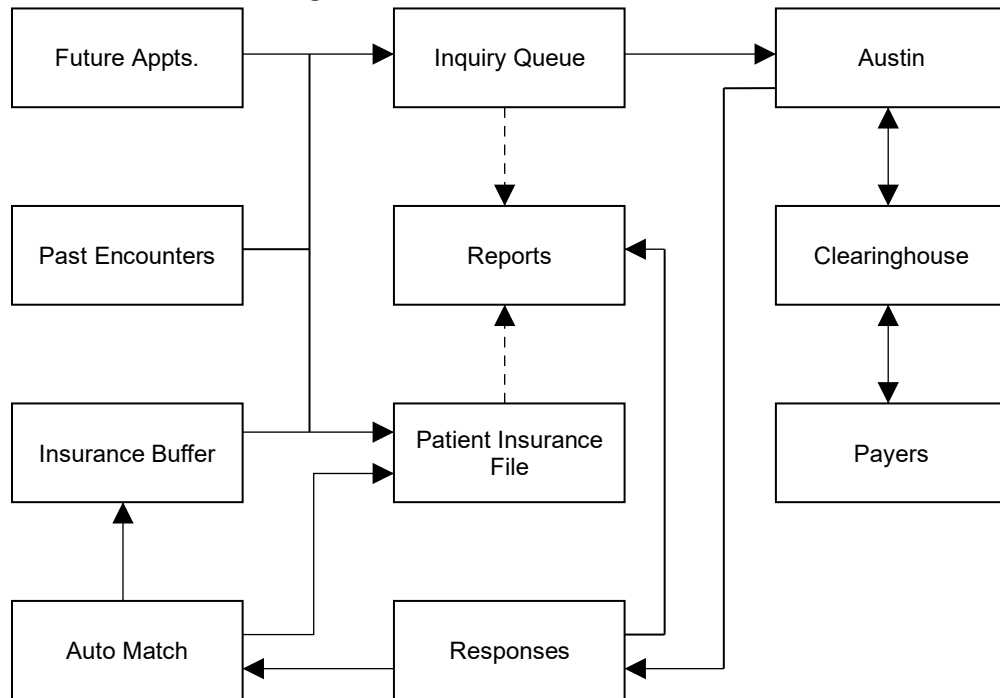

Automatic updates are made only when a response meets pre-determined criteria. The criteria vary slightly depending upon the situation (e.g., Non-Medicare insurance when the Patient is the Insurance Subscriber will be different from Non-Medicare insurance when the Patient is a dependent of the Insurance Subscriber).

Below is an example of some of the criteria:

1. Automatic Update Setting = Yes
2. Subscriber ID (VistA) = Subscriber ID (271 Response)
3. Subscriber DOB (VistA) = Subscriber DOB (271 Response)
4. Subscriber's Name (VistA) = Subscriber Name (271 Response)
5. Group Number (VistA) = Group Number (271 Response)

NOTE: The Automatic Update Setting is also referred to as the Trusted Payer Flag.

1.4 National Insurance Payers

In order for the various VistA sites to be able to request eligibility information from the various payers, a national VA insurance payer list has been established. The national payer list provides a standard identification system for all payers that are participating in this process. Each VistA site has the ability to link the insurance companies in their own database to the appropriate payer in the national payer list. This standardizes the identification of the payer to which each inquiry will be directed.

Figure 3: Flowchart of Inquiries from VistA to Payers and Responses from Payers to VistA

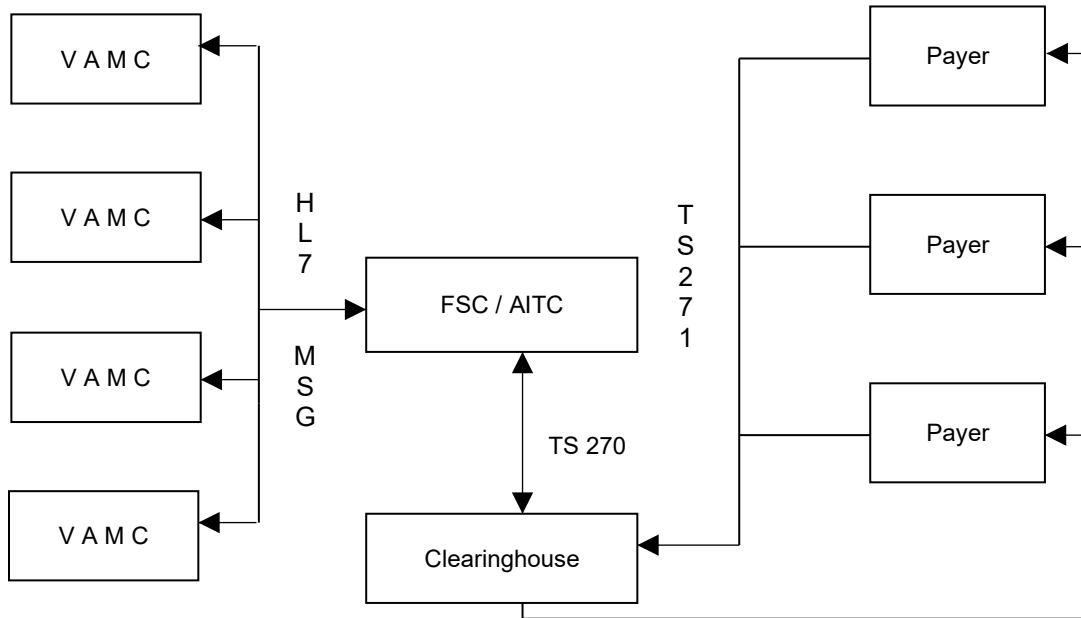

2 Site Parameters

Each VistA site can use the **IV site parameters** to configure some aspects of the eIV and Interfacility Insurance Update (IIU) software to meet a site's unique requirements.

Table 2: IV Site Parameters – General (Editable)

General Parameter (Editable)	Definition
Insurance Import Enabled	When this field is set to '1' (YES), the insurance policies will be imported related to the background execution of remote query. If this field is set to '0' (NO), the insurance policies will NOT be imported in the buffer.
HMS Directory	The name of the directory where Extract / Result files are stored as needed by HMS Data Extractor.
EII Active	Enable / activate eII Software? YES / NO
E1 Transactions Enabled	When this field is set to '1' (YES), E1 transactions may be created and transmitted to the pharmacy payer. If this field is set to '0' (NO), E1 transactions may not be created.
IIU Enabled	When enabled, the receiving VAMC will evaluate the possibility of storing the active verified policy in the buffer. When not enabled, the receiving VAMC will NOT store the policy in the buffer.

General Parameter (Editable)	Definition
Medicare Payer	Medicare entry from the Payer file (#365.12). It is used to identify the Medicare payer for the insurance buffer lists and any other applications that need to know which payer is the Medicare WNR payer.
eIV No Group # Auto-Update	Select a value which represents how long ago a policy expiration date must be older than to evaluate eIV responses without a group number for auto-update consideration. This only applies when a patient file contains a single active policy and one or more expired policies for the same insurance company. Value must be a number between 7-180 days.
Daily Buffer Rpt Mail Group	Enter a @VA.GOV Outlook email address that will receive the Daily Buffer Report (Summary Version).

Table 3: IV Site Parameters – eIV Parameters (Non-editable)

eIV Parameters (Non-editable)	Definition
Freshness Days	How frequently should insurance information be re-verified in days? 7–180 Days This value is controlled by FSC via an HL7 message.
Medicare Freshness Days	How frequently should Medicare insurance information be re-verified in days? 181-545 Days This value is controlled by FSC via an HL7 message.
Timeout Days	Number of days that will define a communication timeout. 1–7 Days This value is controlled by FSC via an HL7 message.
Retry Flag	Should an eIV Inquiry retransmit if no response is received? YES / NO This value is controlled by FSC via an HL7 message.
Timeout Mailman Msg	Send a mail message for each communication timeout? YES / NO
Number of Retries	Number of times to retry an eIV transmission. 0–5 Days
Default STC	Default Service Type Code to be used on the eIV 270 transmissions.
Mail Group	To which mail group should the eIV Statistical Report and other eIV messages be sent?

eIV Parameters (Non-editable)	Definition
Master Switch Realtime	<p>"YES" allows real time 270 transactions to be created and transmitted to the Eligibility Communicator (EC). YES / NO</p> <p>This value is controlled by FSC via an HL7 message.</p>
Master Switch Nightly	<p>YES / NO.</p> <p>"YES" allows the following to occur when the eInsurance Night Process is run: eIV extracts run and create 270 transactions, an eIV registration message is sent to the EC, eIV sends 270 transactions upon successful exchange of eIV registration message, the morning statistical report is scheduled to run at a given time (Daily Mailman Msg), the morning eIV registration message with statistics is scheduled to be created and sent to EC at a given time (Daily Mailman Msg).</p> <p>"NO" prevents all of the tasks listed above from occurring.</p> <p>This value is controlled by FSC via an HL7 message.</p>
CMS MBI Payer	<p>The National Payer used for MBI transactions. This field stores a pointer to the Payer File (#365.12).</p> <p>This value is controlled by FSC via an HL7 message.</p>
HL7 Max #	<p>Allows the restriction of the daily number of HL7 messages created and sent during the HL7 process for eIV during the eInsurance Night Process. 1–99999 Messages</p> <p>This value is controlled by FSC via an HL7 message.</p>
EICD Payer (Electronic Insurance Coverage Discovery)	<p>The National Payer used for EICD transactions. This field stores a pointer to the Payer File.</p> <p>This value is controlled by FSC via an HL7 message.</p>
Send MailMan Message if Communication Problem	<p>Defines whether a MailMan message will be sent if a communication problem/failure occurs. YES / NO</p>
Receive MailMan Message, Daily Statistical	<p>Defines whether the eIV Statistical Report will be sent in a MailMan message each day and the statistical data to FSC at the time specified. YES / NO</p> <p>It also defines the time this message would be sent (set to be sent at 7:00 a.m., local time, each day) "at 0700".</p> <p>If the system is set to send an eIV Statistical Report it will be sent to the Messages Mail Group (listed above as 'Mail Group').</p>

Table 4: IV Site Parameters – Buffer Cleanup

Buffer Cleanup (Editable)	Definition
Duplicate Buffer Cleanup Active	If this field is set to '1' (YES), the Duplicate Buffer Cleanup will run nightly and reject duplicate buffer entries that contain the same insurance company name, group number, and subscriber ID for a unique patient. If the field is set to '0' (NO), the Duplicate Buffer Cleanup will not reject duplicate buffer entries.
Last Run	Defines when the Duplicate Buffer Cleanup was last run (date and time).

Table 5: IV Site Parameters – Batch Extracts: Buffer Extract

Batch Extracts section: Buffer Extract (Non-editable)	Definition
On/Off	Buffer Extract will be turned on.
Start Days From Today	Displayed as Today, due to the fact that the Buffer Extract attempts to verify all user editable buffer entries that have not been processed by eIV.
Days After Start	Displayed as Today, due to the fact that the Buffer Extract attempts to verify all user editable buffer entries that have not been processed by eIV.
Freq.	How frequently should insurance information be re-verified in days? Typically, this is set to 180 days.
Maximum # to Extract/Day	Maximum number of records extracted and available to be transmitted to FSC each day. Max is typically set to 99999. Valid values are 10-99999. This value is controlled by FSC via an HL7 message.

Table 6: IV Site Parameters – Batch Extracts: Appointment Extract

Batch Extracts section: Appointment Extract (Non-editable)	Definition
On/Off	Appointment Extract will be turned on.
Start Days From Today	Appointment extracts will search for Appointments scheduled starting "Today".

Batch Extracts section: Appointment Extract (Non-editable)	Definition
Days After Start	Appointment extracts will search for appointments scheduled for the next X number of days from the Start Date. X is typically set to 10 days. Valid values are 0-20 days.
Freq.	How frequently should insurance information be re-verified in days? Typically, this is set to 180 days.
Maximum # to Extract/Day	Maximum number of records extracted and available to be transmitted to FSC each day. Max is typically set to 99999. Valid values are 10-99999. This value is controlled by FSC via an HL7 message.

Table 7: IV Site Parameters – Batch Extracts: Non-verified Extract

Batch – Non-verified Extract (This extract is not visible to the user at this time.)	Definition
Active?	Non-Verified Extract will be turned off.
Selection Criteria #1	Non-Verified Extract will be turned off.
Selection Criteria #2	Non-Verified Extract will be turned off.
MAXIMUM EXTRACT NUMBER	Non-Verified Extract will be turned off.

Table 8: IV Site Parameters – Batch Extracts: EICD Extract

Batch Extracts section: EICD Extract (Non-editable)	Definition
On/Off	EICD Extract will be turned on.
Start Days From Today	EICD Extract will search for Appointments scheduled X days from Today. X is typically set to 31 days. Valid values are 0-31 days. This value is controlled by FSC via an HL7 message.
Days After Start	EICD Extract will search for X number of days from the Start Date. X is typically set to 9 days. Valid values are 0-20 days. This value is controlled by FSC via an HL7 message.

Batch Extracts section: EICD Extract (Non-editable)	Definition
Freq.	How often a Veteran's insurance can be picked up by this extract. Typically, no more than once a year (365 Days). Valid values are 90-365 days. This value is controlled by FSC via an HL7 message.
Maximum # to Extract/Day	Maximum number of records extracted and available to be transmitted to FSC each day. Max is typically set to 99999. Valid values are 10-99999. This value is controlled by FSC via an HL7 message.

Table 9: IV Site Parameters – IIU (non-editable)

IIU Parameters (Non-editable)	Definition
Max Days of Recent Visit	A patient must have recently visited the receiving VAMC within this number of days, for the possibility of storing the active verified policy in the buffer. Valid values are 0-500 days. This value is controlled by FSC via an HL7 message.
Purging Sent Records	Number of days to retain previously sent policies that are stored in the Interfacility Insurance Update file (#365.19) before purging. Valid values are 3-365 days. This was set to 180 days to retain IIU data as its initial value.
Min Days Before Sharing Again	Minimum number of days allowed since the last time the policy information was sent/shared to another VAMC via IIU. Valid values are 1-500 days. This value is controlled by FSC via an HL7 message.
Purging Received Records	Number of days to retain previously received Interfacility Insurance Update file (#365.19) before purging. Valid values are 15-60 days. This was set to 30 days to retain IIU data as its initial value.
IIU Master Switch	YES / NO. This field is used in VistA to allow/prevent the sharing of verified active policies to other VAMCs via the IIU process. "YES" allows the following to occur when the eInsurance Night Process is run verified active policies are shared with other VAMCs. A 'NO' means the IIU processing is Disabled. This value is controlled by FSC via an HL7 message.

IIU Parameters (Non-editable)	Definition
Purging Candidate Records	Number of days to retain candidate records in the Interfacility Insurance Update file (#365.19) that are still waiting to be sent to other VAMCs before purging. Valid values are 3-14 days. This was set to 7 days to retain IIU data as its initial value.

2.1 Define General Parameters

1. Access the SYST MCCR System Definition Menu.
2. Access the SITE MCCR Site Parameter Display/Edit option.
3. At the **Select Action:** prompt, enter **IV** for Ins. Verification.

```

MCCR Site Parameters          Dec 10, 2010@11:15:16          Page:    1 of    1
Display/Edit MCCR Site Parameters.
Only authorized persons may edit this data.

IB Site Parameters              Claims Tracking Parameters
  Facility Definition           General Parameters
  Mail Groups                  Tracking Parameters
  Patient Billing               Random Sampling
  Third Party Billing           HCSR Parameters
  Provider Id
  EDI Transmission

Third Party Auto Billing Parameters  Insurance Verification
  General Parameters            General Parameters
  Inpatient Admission           eIV Parameters
  Outpatient Visit              eIV Batch Extracts
  Prescription Refill           IIU Parameters

                                Enter ?? for more actions
IB Site Parameter              AB Automated Billing      EX Exit
CT Claims Tracking             IV Ins. Verification
Select Action: Quit// IV      Ins. Verification

```

The following screen will be displayed.

```

IV Site Parameters          Jul 24, 2023@13:33:32          Page:    1 of    3
Only authorized persons may edit this data.

General Parameters (editable)
  Misc. Settings
    Insurance Import Enabled: NO
    HMS Directory: /home/kidsfiles/
    EII Active: NO
    E1 Transactions Enabled: YES

  IIU Settings
    IIU Enabled: YES

  eIV Settings
    Medicare Payer: CMS

```

eIV No Group # Auto-Update: 180
Daily Buffer Rpt Mail Group: XXX@VA.GOV

+ Enter ?? for more actions
GP General Parameters FB Fix Corrupt Buffers
BC Duplicate Buffer Cleanup EX Exit
Select Action: Quit//

IV Site Parameters Jul 24, 2023@14:13:10 Page: 2 of 3

eIV Parameters (non-editable)
Freshness Days: 180 Medicare Freshness Days: 365
Timeout Days: 5 Retry Flag: NO
Timeout Mailman Msg: NO Number of Retries: 1
Default STC: 30 Mail Group: IBCNE EIV MESSAGE
Master Switch Realtime: YES Master Switch Nightly: YES
CMS MBI Payer: CMS MBI ONLY HL7 Max #: 99999
EICD Payer: ELECTRONIC COVERAGE DISCOVERY

Send MailMan Message if Communication Problem: YES
Receive MailMan Message, Daily Statistical: YES at 0700

Buffer Cleanup
Duplicate Buffer Cleanup Active: YES Last Run: DEC 30, 2024 (10:00PM)

+ Enter ?? for more actions
GP General Parameters FB Fix Corrupt Buffers
BC Duplicate Buffer Cleanup EX Exit
Select Action: Quit//

IV Site Parameters Nov 06, 2023@13:28:10 Page: 3 of 3

Only authorized persons may edit this data.

+
Batch Extracts
Extract Start Days Days After Maximum # to
Name On/Off From Today Start Freq. Extract/Day
Buffer ON Today Today 180 99999
Appt * ON Today 10 180 99999
EICD ON 31 9 365 99999

* Appt extract - Medicare frequency is 365 days

IIU Parameters (non-editable)
Max Days of Recent Visit: 340 Purging Sent Records: 180
Min Days Before Sharing Again: 170 Purging Received Records: 30
IIU Master Switch: YES Purging Candidate Records: 7

+ Enter ?? for more actions
GP General Parameters FB Fix Corrupt Buffers
BC Duplicate Buffer Cleanup EX Exit
Select Action: Quit// GP General Parameters

4. At the **Select Action:** prompt, enter **GP** for General Parameters.

5. At the **Medicare Payer:** prompt, enter the appropriate value.

6. At the **HMS Directory:** prompt, enter the directory appropriate for your site.
7. At the **EII Active:** prompt, enter the appropriate value.
8. At the **E1 Transactions Enabled:** prompt, enter the appropriate value.
9. At the **IIU Enabled:** prompt, enter the appropriate value.
10. At the **eIV No Group # Auto-Update:** prompt, enter the appropriate value.
11. At the **Insurance Import Enabled:** prompt, enter the appropriate value.
12. At the **Daily Buffer Rpt Mail Group:** prompt, enter the appropriate value.

NOTE: The FRESHNESS DAYS prompt has been removed with patch IB*2*506. This is no longer editable and system is set to 180.

The MEDICARE FRESHNESS DAYS prompt was added with patch IB*2*659. This prompt is non-editable, and the system is set to 365.

The DAILY MAILMAN MSG prompt has been removed as it is no longer optional.

The DAILY MSG TIME prompt has been removed with patch IB*2*506. The system is set to automatically send the daily message at 0700 local time.

The MESSAGES MAILGROUP: prompt has been removed by patch IB*2*549. This field is no longer editable and is set to IBCNE EIV MESSAGE.

The HL7 RESPONSE PROCESSING prompt has been removed with patch IB*2*506. This field is no longer editable and the system is set to Immediate.

Patch IB*2*416 removed the prompt HL7 MAXIMUM NUMBER. A site can no longer limit the number of daily inquiries.

The Store Service Type code entry functionality has been removed by patch IB*2*549. This field is no longer editable and is set to 30.

The FAILURE MAILMAN MSG: prompt has been removed by patch IB*2*549. This field is no longer editable and is set to Yes.

The IIU ENABLED prompt was added with patch IB*2*687. This prompt is editable.

The INSURANCE IMPORT ENABLED prompt was added with patch IB*2*763. This prompt is editable.

The DAILY BUFFER RPT MAIL GROUP prompt was added with patch IB*2*771. This prompt is editable.

The E1 TRANSACTIONS ENABLED prompt was added with patch IB*2*822. This prompt is editable.

2.2 Define Batch Extract Parameters

Patch IB*2*438 removed the ability for the sites to define Batch Extract Parameters.

NOTE: Patch IB*2*416 removed the ability for sites to define Buffer and Appointment parameters. No insurance parameters were removed as no inquiries will be sent for patients w/o insurance.

Patch IB*2*438 set Non-verified parameters to Not Active and Non-editable.

Patch IB*2*438 updated the eIV system to no longer check for freshness days ('Days between electronic re-verification checks' defined in the MCCR site parameter) for eligibility benefit inquiries that are available in the buffer and are awaiting transmission in the transmission queue.

Appointment extracts will skip policies whose last verified date is less than the freshness days from creating buffer entries. (Medicare policies have a different freshness days parameter than non-Medicare policies.)

Patch IB*2*631 added the Electronic Insurance Coverage Discovery (EICD) extract that will look for insurance coverage for patients with appointments within a date range but no more than once a year.

2.3 Fix or List Corrupt Buffers

The FIX CORRUPT BUFFERS action is a restricted action that frees up patient records when no buffer entry is found. The Fix Corrupt Buffers action also allows a user to display a list of corrupt buffer entries due to a modification made with patch IB*2*763.

Example of Fix Corrupt Buffer:

```
Fix or List Corrupt Buffers? List// f  Fix
Last run was on Jun 06, 2023
Do you want the details? No// y  YES
Run For: 518-BEDFORD VAMC
Started: Jun 06, 2023@20:00          Completed: Jun 06, 2023@20:00
FIRSTNAME LASTNAME, ran 'Fix Corrupt Buffer' on Jun 06, 2023
- Clean-up of corrupted #355.33 records has completed.
-----
# of corrupt buffer entries corrected (stopped ins. verification): 0
# of corrupt Accepted/Rejected buffer entries corrected: 0
# of corrupt buffer entries removed (bad zero node): 0
Total entries removed: 0
```

```
Total entries corrected: 0
Do you want to run Fix Corrupt Buffer? No//Yes
Task: 867442 Clean-up of corrupted records in file #355.33
      scheduled for Jul 19, 2023@20:00
Type <Enter> to continue or '^' to exit:
```

Example of List Corrupt Buffers:

```
Fix or List Corrupt Buffers? List// List
Last run was on May 29, 2023

Do you want the details? NO// YES

Run For: 517-BECKLEY VAMC
Started: May 29, 2023@09:41          Completed: May 29, 2023@09:41

Date Created^Buffer IEN^Patient
5/1/23^XXXX^LASTNAME,FIRSTNAME
5/1/23^XXX^
^XXX^ LASTNAME,FIRSTNAME
**End of Report**

Do you want to run the List of Corrupt Buffers? NO// NO
Not creating List of Corrupt Buffers.

Type <Enter> to continue or '^' to exit:
```

2.4 Duplicate Buffer Cleanup

The Duplicate Buffer Cleanup action if set to 'YES' will automatically reject duplicate entries in the buffer. This modification was made with patch IB*2*806.

1. At the **Select Action:** prompt, enter **BC** for Duplicate Buffer Cleanup.
2. At the **Duplicate Buffer Cleanup:** prompt, enter the appropriate value.

NOTE: Patch IB*2*806 added the Duplicate Buffer Cleanup action which will run nightly 10:00pm (local time) and reject duplicate buffer entries that contain the same insurance company name, group number, and subscriber ID for a unique patient.

3 Payers

The VistA Payer file (#365.12) is a VA national file of insurance companies within each VistA system. It is automatically updated when a payer is enrolled and registered at the FSC by the eBusiness Solutions Office. It is non-editable at the facility level and the same data exists in this file at all VistA locations. However, the VistA locations do have the option to locally enable / not enable payers.

When a 270 Health Care Eligibility Benefits Inquiry is constructed, it is this payer name in the Payer file (#365.12), not the Insurance Company name, which is transmitted with the inquiry. In order for an individual insurance company to participate in the eIV process, it must be linked to a payer in the Payer file. It is important to note that:

- An insurance company can be linked to only one payer.
- Many insurance companies can be linked to a single payer.
- The payer must also be eIV Locally Enabled in order for it to be eligible for inclusion in the eIV process.

3.1 Link Insurance Company to Payers using Link Insurance Company to Payers

The **Link Insurance Companies to Payers** option provides a tool for identifying potential matches of active Insurance Companies with Professional and Institutional IDs that are not linked to a particular Payer. Professional and Institutional Payer Primary ID fields correspond respectively to the EDI ID NUMBER – PROF and EDI ID NUMBER – INST fields in the Insurance Company Editor.

1. Access the PI Patient Insurance Menu.
2. Access the PM Payer Maintenance option.

NOTE: Users must hold the IBCNE EIV IIU MAINTENANCE security key to access this option.

3. Access the LI Link Insurance Companies to Payers option.

NOTE: The system finds potential matches for users based on matching Payer Primary ID fields in the Insurance Company Editor. Please note that all matches are not definitive and should be linked at the user’s discretion.

The following screen of Payers who have potentially matching insurance company entries will be displayed:

Payer Maintenance		Sep 22, 2009@14:26:21	Page: 1 of 1
Payers with potential matches to active insurance companies.			
	Payer Name	#	Potential Matches
1	IBpayer One	2	
2	IBpayer Two	1	
3	IBpayer Three	3	
4	IBpayer Four	1	

```
Enter ?? for more actions
EE Expand Entry          EX Exit
Select Action: Quit//
```

4. At the **Select Action:** prompt, enter **EE** for **Expand Entry**.
5. At the **Select entry to Expand, by line #: (1-5):** prompt, enter 2 for this example.

The following screen will be displayed:

```
Payer Expand Screen          Sep 22, 2009@14:45:22          Page: 1 of 1
PAYER: IBpayer Two          Prof. EDI#:11111  Inst. EDI#:11111

Insurance Company Name - Active Only
Insurance Company Name      Address                Prof#  Inst#
1  IBinsurance Two A        PO BOX 5555 ANYTOWN, PA  11111  11111
2  IBinsurance Two B        PO BOX 5555 ANYCITY OHIO 11111  11111

Enter ?? for more actions
PL Print List                EX Exit
LP Link Payer
Select Action: Quit//
```

6. At the **Select Action:** prompt, enter **LP** for **Link Payer**.
7. At the Select 1 or more Insurance Company Entries: prompt, enter 1-2 for this example.
8. At the **OK to proceed? YES//** prompt, press **RETURN** to accept the default of **YES**.

NOTE: Patch IB*2*416 provided the ability to link more than one insurance company to a payer at one time.

Users also have the option to print a list of insurance companies that may match a Payer. The list can be printed to a printer or to the screen.

```
Select 1 or more Insurance Company Entries: (1-2): 1-2

You have selected 2 insurance companies
to be linked to payer IBpayer Two.
OK to proceed? YES//

Link process is complete.
You may view/edit this relationship by using the
Insurance Company Entry/Edit option.

Enter RETURN to continue or '^' to exit:
```

To print the details, go back to **Expand Entry** and select **Print List** as detailed below.

1. Access the PI Patient Insurance Menu.
2. Access the PM Payer Maintenance option.
3. Access the LI Link Insurance Companies to Payers option.
4. At the **Select Action:** prompt, enter **EE** for **Expand Entry**.
5. At the Select entry to Expand, by line #: (1-5): prompt, enter 2 for this example.
6. At the **Select Action:** prompt, enter **PL** for **Print List**.
7. At the **Device://Home:** prompt enter **RETURN** to display to the screen or enter a device name.

The following screen will be displayed.

Payer Expand Screen		Sep 22, 2009@14:45:22	Page:	1 of	1
PAYER: IBpayer Two		Prof. EDI#:11111	Inst. EDI#:11111		
Insurance Company Name - Active Only					
	Insurance Company Name	Address	Prof#	Inst#	
1	IBinsurance Two A	PO BOX 5555 ANYTOWN, PA	11111	11111	
2	IBinsurance Two B	PO BOX 555555 ANYCITY OHIO	11111	11111	
Enter RETURN to continue or '^' to exit:					

3.2 Link Insurance Company to Payers using Insurance Company Editor

When VistA is unable for any reason to identify an insurance company as a potential match to a payer, users can link the insurance company to a payer from within the **Insurance Company Editor**.

1. Access the PI Patient Insurance Menu.
2. Access the EI Insurance Company Entry/Edit option.
3. At the **Select INSURANCE COMPANY NAME:** prompt, enter IBinsurance Two A for this example.

The following screen will be displayed:

Insurance Company Editor		Sep 22, 2009@15:11:57	Page:	1 of	9
Insurance Company Information for: IBinsurance Two A					
Type of Company: HEALTH INSURANCE			Currently Active		
Billing Parameters					
Signature Required?: NO		Type Of Coverage: HEALTH INSURAN			
Reimburse?: WILL REIMBURSE		Billing Phone: 555-555-5555			
Mult. Bedsections: YES		Verification Phone: 555-555-5555			
One Opt. Visit: NO		Diff. Rev. Codes:			
Precert Comp. Name:		Amb. Sur. Rev. Code:			
Precert Phone: 555-555-5555		Rx Refill Rev. Code:			

```

Precert Portal:

Filing Time Frame: 1(0 YEAR(S))

                                EDI Parameters
                                Transmit?: YES-LIVE                Insurance Type: GROUP POLICY
+      Enter ?? for more actions
BP Billing/EDI Param      RE Remarks                        DC Delete Company
AD Billing Addresses      SY Synonyms                      VP View Plans
AC Associate Companies    EA Edit All                          EX Exit
ID Prov IDs/ID Param     AI (In)Activate Company
PA Payer                  CC Change Insurance Co.
Select Action: Next Screen// PA Payer                                >>>

PAYER: IBpayer Two

```

4. At the **Select Action:** prompt, enter **PA** for **Payer**.
5. At the **Payer:** prompt, enter **??** to see a list of Payers.
6. At the **Payer:** prompt, enter **IBpayer Two** for this example.

NOTE: Users must hold the **IBCNE EIV IIU MAINTENANCE** security key to access the (PA) Payer action.

To view the linked Payer for a particular insurance company, users may access **VI** for **View Insurance Company**.

The following screen will be displayed:

```

Insurance Company Editor      Jul 07, 2010@13:55:50      Page:      8 of      9
Insurance Company Information for: IBinsurance Two A
Type of Company: HEALTH INSURANCE      Currently Active
+
Insurance Company Editor      Jul 07, 2010@13:55:50      Page:      8 of      9
Insurance Company Information for: IBinsurance Two A
Type of Company: HEALTH INSURANCE      Currently Active
+
                                Payer: PAYER1

VA National ID: VA10          CMS National ID:
Deactivated: NO

                                Payer Application: eIV
Nationally Enabled: YES      FSC Auto-Update: YES
Locally Enabled: YES

                                Payer Application: IIU
Nationally Enabled: YES      Receive IIU Data: NO
Locally Enabled: YES

+      Enter ?? for more actions
BP Billing/EDI Param      RE Remarks                        DC Delete Company
AD Billing Addresses      SY Synonyms                      VP View Plans

```

```

AC Associate Companies      EA Edit All                EX Exit
ID Prov IDs/ID Param      AI (In)Activate Company
PA Payer                  CC Change Insurance Co.
                               >>>
Select Action: Next Screen//

```

To view the linked payer for an insurance company, go back to the **Patient Insurance Menu** and select **View Insurance Company**.

1. Access the PI Patient Insurance Menu.
2. Access the VI View Insurance Company option.
3. At the Select INSURANCE COMPANY NAME: prompt, enter IBinsurance Two A for this example.

The following screen will be displayed:

```

Insurance Company Editor      Sep 22, 2009@15:11:57      Page: 1 of 8
Insurance Company Information for: IBinsurance Two A
Type of Company: HEALTH INSURANCE      Currently Active

      Billing Parameters
Signature Required?: NO      Type Of Coverage: HEALTH INSURAN
      Reimburse?: WILL REIMBURSE      Billing Phone: 555-555-5555
Mult. Bedsections: YES      Verification Phone: 555-555-5555
      One Opt. Visit: NO      Diff. Rev. Codes:
Precert Comp. Name:      Amb. Sur. Rev. Code:
      Precert Phone: 555-555-5555      Rx Refill Rev. Code:
      Precert Portal:

      Filing Time Frame: 1(0 YEAR(S))

      EDI Parameters
      Transmit?: YES-LIVE      Insurance Type: GROUP POLICY
Inst Payer Primary ID: XXXXX      Prof Payer Primary ID: XXXXX
+      Enter ?? for more actions      >>>
CC Change Insurance Co.      EX Exit
Select Action: Next Screen//

```

3.3 Payer Edit

To edit the payer information users must use the **Payer Maintenance Menu**. The **Payer Edit** option is restricted to users with the **IBCNE EIV IIU MAINTENANCE** security key.

1. Access the PI Patient Insurance Menu.
2. Access the PM Payer Maintenance Menu.
3. Access the **PE Payer Edit** option.
4. The user will be prompted with the chance to filter the Payer Name by begins with or contains. At this same prompt, the user may select list to view all available payers.

- When selecting begins with or contains, at the **Payer Name:** prompt, enter **IBPAYER TWO** for this example.

NOTE: Users must hold the **IBCNE EIV IIU MAINTENANCE** security key to access Payer Edit.

The following screen will be displayed:

```

                                Payer Edit

This option displays the data in the Payer file for a given payer. You
may only edit site controlled fields and most fields are not site controlled.
Site controlled fields cannot be edited for a deactivated payer.

                                Payer Name: IBPAYER TWO
                                VA National ID: VA685
                                CMS National ID:
                                Blue Payer: YES
                                Inst Electronic Bill ID: 12B23
                                Prof Electronic Bill ID: SB810
                                Date/Time Created: 09/25/2003@06:31:19

Payer Application: eIV                                Payer Application: IIU
-----
Nationally Enabled: Enabled                            Nationally Enabled: Enabled
Future Service Days: 30                               IIU Locally Enabled: Enabled
Past Service Days: 9999                              Receive IIU Data: YES
Auto-update Pt. Insurance: YES
eIV Locally Enabled: Enabled

eIV App > eIV Locally Enabled: Enabled//
IIU App > Receive IIU Data: YES//

```

- At the **eIV App > eIV Locally Enabled:** prompt, users can type **Enabled** or disable (**Not Enabled**) . Press **RETURN** to accept the default for this example.
- At the **IIU App > Receive IIU Data:** prompt, users can select **NO** or **YES** for a Payer. Press **RETURN** to accept the default for this example.

NOTE: Users can only type Enabled or Not Enabled (disable) a Payer for eIV under the eIV **Locally Enabled field** and select **NO** or **YES** for **Receive IIU Data** when applicable. The remainder of the Payer information is set by FSC.

WARNING: A payer must be nationally enabled and locally enabled for 270 / 271 Health Care Eligibility Inquiry and Response messages to be transmitted.

NOTE: Patch IB*2*416 removed the ability for patient SSNs be transmitted as IDs in a 270 Health Care Eligibility Inquiry so those prompts were removed from Payer Edit.

NOTE: Users can select **YES** for **Receive IIU Data** in order to show policies received from IIU for this payer in the buffer.

4 Process Insurance Buffer

The **Process Insurance Buffer** option provides six buffer views from which users may process entries and thus update patients' insurance information in the patient file:

- **Complete Buffer** – Contains all records that can be found on the other Insurance Buffer views (Positive, Negative, Medicare, Failure and ePharm) in addition to the following types of records: eIV inquiries waiting for responses "?", manual entries <blank> , ambiguous responses "#", responses that include the value "%".
- **Positive Buffer** – Positive 271 Health Care Eligibility Benefits Responses (that failed to meet the auto-update criteria and are non-Medicare). These responses may have one of the symbols "+" or "\$".
- **Negative Buffer** – Negative 271 Health Care Eligibility Benefits Responses (non-Medicare). These responses have the eIV symbol "-".
- **Medicare Buffer** – Positive, Negative or Ambiguous 271 Health Care Eligibility Benefits Responses. These responses may have any of the eIV symbols. (Refer to section 4.1.1 below).
- **Failure Buffer** – Contains only non-Medicare records that have an eIV symbol of "!".
- **ePharm Buffer** – Contains insurance billable pharmacy data.
- **TRICARE / CHAMPVA** – Entries that contain the word TRICARE or CHAMPVA in the insurance company name.

4.1 Status Flags

4.1.1 Buffer Symbols

Table 10: Buffer Symbols

Flag	Meaning
(blank)	Inquiry not yet sent.
+	Matching patient data was found at payer, payer indicates active policy.
-	Matching patient data was found at payer, payer indicates expired policy.

Flag	Meaning
#	eIV is unable to determine if payer indicates active or expired policy. OR matching patient data was NOT found at payer. OR response did not return requested value (may include an additional message with explanation).
%	Response returned the requested value.
?	Inquiry was sent, waiting for response.
!	eIV was unable to send an inquiry for this entry. A manual correction is required before eIV can send inquiry. A descriptive error message will be displayed on the last screen of the expanded buffer entry.
\$	Buffer entry was escalated to user with appropriate security key.
a	ePharmacy E1 transaction status is Approved.
r	ePharmacy E1 transaction status is Rejected.

4.1.2 Buffer Entry Status Flags

Flag	Meaning
d	Patient appears on more than one buffer view (Duplicate).

4.1.3 Patient Status Flags

Table 11: Patient Status Flags

Flag	Meaning
i	Patient currently has active insurance on file
I	Patient is currently admitted as an inpatient
E	Patient is deceased (expired)
Y	Patient is required to pay VA copayment for incurred charges according to Means Test
H	Patient has charges on hold
P	Patient has potential new insurance policy

4.1.4 Buffer Entry Source of Information Indicators

Table 12: Buffer Entry Source of Information Indicators

Letter	Meaning
I	Interview
P	Pre-Registration
M	Medicare
D	Data Match
E	eIV
R	ICB Card Reader
V	IVM
H	HMS
C	Contract Services
X	ePharmacy
F	Interfacility Insurance Update
T	Insurance Import
U	Community Care Network
B	Purchased Care Fee-Basis
O	Purchased Care Other
N	Insurance Intake
S	Insurance Verification
A	Veteran Appt Request
K	Kiosk
J	MYVA Health Journal
W	Electronic Health Record
G	Adv Med Cost Mgmt Solution

4.1.5 Insurance Entry Update Methods

Table 13: Insurance Entry Update Methods

Letter	Meaning
M	Merge - Data from the buffer entry will be saved to the insurance entry ONLY if the corresponding data field in the insurance entry is blank.
O	Overwrite - ALL non-blank data in the buffer entry will be saved to the insurance entry. If a buffer entry field has a value it will be saved to the corresponding insurance entry field. Blank insurance fields will be filled and existing insurance data replaced.
R	Replace - ALL fields in the buffer entry will be saved to the insurance entry, including blank fields. Therefore, all data in the insurance entry will be deleted then completely replaced by the buffer entry.
N	No Change - This option may be used to identify the Insurance entry that corresponds to a buffer entry without actually changing any of the Insurance Information. The Buffer data is ignored.
I	Individually Accept - This option may be used to accept only non-blank specific fields from the buffer entry into the Insurance entry. Only those values accepted by the user will replace the corresponding fields in the Insurance entry.

See [Appendix B – eIV Error Message Descriptions](#) for a detailed list of error messages associated with entries that were created because a 270 Health Care Eligibility Benefits Inquiry could not be transmitted.

4.2 Buffer Actions

All views provide users the same actions for each buffer view.

NOTE: Patients with no insurance on file will not be included in the nightly Buffer Extract.

These following actions are available in **Process Insurance Buffer**:

- **PE** – Process Entry
- **RE** – Reject Entry
- **EE** – Expand Entry
- **AE** – Add Entry
- **ST** – Sort List
- **CC** – Check Ins Co's

- **PB** – Positive Buffer
- **NB** – Negative Buffer
- **MB** – Medicare Buffer
- **FB** – Failure Buffer
- **RX** – ePharm Buffer
- **EX** – Exit
- **CB** – Complete Buffer
- **TC** – TRICARE/CHAMPVA
- **BR** – Buffer Refresh

These following actions are hidden, but available in **Process Insurance Buffer**:

- **+** – Next Screen
- **-** – Previous Screen
- **UP** – Up a Line
- **DN** – Down a Line
- **>** – Shift view to Right
- **<** – Shift view to Left
- **FS** – First Screen
- **LS** – Last Screen
- **GO** – Go to Page
- **RD** – Re Display Screen
- **PS** – Print Screen
- **PL** – Print List
- **SL** – Search List
- **ADPL** – Auto Display (On/Off)
- **Q** – Quit

4.2.1 Process Entry

Processing an entry in a **Buffer View** results in updating the patient's insurance and removing the entry from the buffer. Once users access **Process Entry**, they will have access to the following additional actions:

- **Accept Entry** – Allows users to update the patient’s insurance and remove the entry from the buffer
- **Reject Entry** – Allows users to remove the entry from the buffer without updating the patient’s insurance
- **Compare Entry** – Allows users to compare the data in the buffer with the data in the patient’s insurance
- **Expand Entry** – Allows users to Expand an Entry – Refer to Section 4.2.3
- **Insurance Co / Patient** – Allows users to view specific information about an insurance company’s available policies

To process an entry, complete the following steps:

1. Access the PI Patient Insurance Menu.
2. Access the BI Process Insurance Buffer option.

NOTE: The default Insurance Buffer view is the Positive Insurance Buffer and users can move between views using the action for each view.

Some actions such as Reject Entry are only available to users who hold the **IB INSURANCE SUPERVISOR** key.

The following screen will be displayed:

Complete Buffer		Oct 19, 2015@16:16:01		Page: 1 of 2	
Sorted by: Patient Name					
	Patient Name	Insurance Co	Subscr Id	S Entered	iIEYHP
1	! IBPATIENT,ONE	XXXX IBINSURANCE,ONE	SUB ID XXXX	I 10/09/98	I P
2	! IBPATIENT,TWO	XXXX IBINSURANCE,ONE	SUB ID XXXX	E 09/10/15	
3	! IBPATIENT,THREE	XXXX IBINSURANCE,ONE	SUB ID XXXX	E 09/10/15	
4	! IBPATIENT,FOUR	XXXX IBINSURANCE,TWO	SUB ID XXXX	P 09/10/15	
5	! IBPATIENT,FIVE	XXXX IBINSURANCE,FOUR	SUB ID XXXX	P 09/10/15	
6	! IBPATIENT,SIX	XXXX IBINSURANCE,FOUR	SUB ID XXXX	P 09/03/15	
7	! IBPATIENT,SEVEN	XXXX IBINSURANCE,FOUR	SUB ID XXXX	P 09/10/15	
8	! IBPATIENT,EIGHT	XXXX IBINSURANCE,FIVE	SUB ID XXXX	P 09/10/15	
9	! IBPATIENT,NINE	XXXX IBINSURANCE,ONE	SUB ID XXXX	I 09/09/15	
10	! IBPATIENT,TEN	XXXX IBINSURANCE,SIX	SUB ID XXXX	I 09/30/15	
11	! IBPATIENT,ELEVEN	XXXX IBINSURANCE,TWO	SUB ID XXXX	I 10/01/15	I
12	! IBPATIENT,TWELVE	XXXX IBINSURANCE,TWO	SUB ID XXXX	P 10/01/15	i H
13	? IBPATIENT,THIRTEEN	XXXX IBINSURANCE,ONE	SUB ID XXXX	E 09/30/15	Y
14	! IBPATIENT,FOURTEEN	XXXX IBINSURANCE,TWO	SUB ID XXXX	P 09/30/15	i H
15	! IBPATIENT,FIFTEEN	XXXX IBINSURANCE,FOUR	SUB ID XXXX	I 09/30/15	i Y
+ Enter ?? for more actions					
PE	Process Entry	ST	Sort List	MB	Medicare Buffer
RE	Reject Entry	CC	Check Ins Co's	FB	Failure Buffer
EE	Expand Entry	PB	Pos. Buffer	RX	ePharm Buffer
AE	Add Entry	NB	Neg. Buffer	EX	Exit
CB Complete Buffer					
TC TRICARE/CHAMPVA					
BR Buffer Refresh					
Select Action: Next Screen//					

3. At the Select Action: prompt, enter PE for Process Entry.
4. At the **Select Buffer Entry(s): (1-15):** prompt, enter **1** for this example.

The following screen will be displayed:

```

Insurance Buffer Process          May 21, 2010@10:21:24          Page: 1 of 1
IBPATIENT,ONE                      XXX-XX-XXXX          DOB: XXX XX,XXXX AGE: XX

          IBinsurance One          (P.O. BOX 555555, ANYCITY, OH)
- IBinsurance One  GRP NUM 11269          PATIEN 10/01/00

          Patient's Existing Insurance
Insurance Company  Group #          Subscriber Id  Holder  Effective Expires
1  IBinsurance Two  GRP NUM 11269  SUB ID XXXX  PATIEN 04/01/95 10/01/00

          Any Group/Plan that may match Group Name or Group Number
Insurance Company  Group Name          Group Number
2  IBinsurance Two  PO BOX 740800  XXXXX          GRP NUM XXXX
3  IBinsurance Two  PO BOX 740800  XXXXX          GRP NUM XXXXX

          Enter ?? for more actions
AE Accept Entry          CE Compare Entry          VP Insurance Co/Patient
RE Reject Entry          EE Expand Entry          EX Exit
Select Action: Quit//
  
```

5. At the **Select Action:** prompt, enter **AE** for Accept Entry.
6. At the **Select Company/Policy: (1-3):** prompt, enter **1** for this example.

The following screen will be displayed:

```

Insurance Data:  Buffer Data          Selected Insurance Company
Company Name:    TEST-1              | BLUE CROSS
Reimburse?:     | WILL REIMBURSE
Phone Number:   |
Billing Phone:  | 877.277.3368
Pre-Cert Phone: | 877.277.3368
Street [Line 1]: | 123 HERE
Street [Line 2]: |
Street [Line 3]: |
City:           | ANYTOWN
State:          | CALIFORNIA
Zip Code:       | 99999
                (bold=accepted on Merge) | (bold=replaced on Overwrite)

Is this the correct INSURANCE COMPANY to match with this Buffer entry? YES

Select the method to update the INSURANCE COMPANY: (M/O/R/N/I): NO CHANGE
  
```

7. At the Is this the correct INSURANCE COMPANY to match with this Buffer entry? Prompt, enter YES.
8. At the Select the method to update the INSURANCE COMPANY: (M/O/R/N/I): prompt, always enter N.

NOTE: VistA has no control over the information that the payers return, so by selecting **N**, the details about the payer in the VistA insurance file will not be changed.

The following screen will be displayed:

```

Patient is a member of this Insurance Group/Plan
Group/Plan Data: Buffer Data                               Selected Group/Plan
Company Name: TEST-1                                     | BLUE CROSS
Is Group Plan?:                                         | YES
Group Name:                                             | BLUE CROSS OF CA
Group Number:                                           | 3485
BIN:
PCN:
Require UR:                                             | NO
Require Pre-Cert:
Require Amb Cert:
Exclude Pre-Cond:
Benefits Assign:                                       | YES
Type of Plan:                                          | ACCIDENT AND HEALTH INSURANCE
                (bold=accepted on merge)              | (bold=replaced on overwrite)

Is this the correct GROUP/PLAN to match with this Buffer entry? YES
Select the method to update the GROUP/PLAN: (M/O/R/N/I): NO CHANGE
```

9. At the Is this the correct Group Plan to match with this Buffer entry? Prompt, enter YES.
10. At the Select the method to update the Group Plan: (M/O/R/N/I): prompt, enter N.

NOTE: VistA has no control over the information that the payers return, so by selecting **N** the details about the payer in the VistA insurance file will not be changed.

The following screen will be displayed:

```

Do you want to Review the AB Y/N? No// YES

Benefit year:
JAN 01, 2001
JAN 20, 2001
JAN 01, 2002
JAN 01, 2016
FEB 05, 2012
FEB 09, 2015

Enter Existing Date or Add New Benefit Year: JAN 1, 2001 (JAN 01, 2001)
```

11. At the Do you want to Review the AB Y/N? prompt, enter YES.
12. At the Enter the Existing Data or Add New Benefit Year prompt, enter the JAN 01, 2001, for this example.

The following screen will be displayed:

Annual Benefits Data	
Benefit Year	: JAN 01, 2001
Policy Information	: BLUE CROSS
Max Out of Pocket	: 33.33
Ambulance Coverage(%)	: 9
Inpatient:	
Annual Deductible	: 23
Per Admis Deduct	: 2
Inpt. Lifetime Max	: 100
Inpt. Annual Max	: 68
Room & Board (%)	: 34
Drug/Alcohol Lifet. Max	: 67.00
Drug/Alcohol Annual Max	: 02
Nursing Home (%)	: 44
Other Inpt. Charges (%)	: 77
Outpatient:	
Annual Deductible	: 38.89
Per Visit Deductible	: 56.12
Enter RETURN to continue or '^' to exit:	
Lifetime Max	: 69.99
Annual Max	: 99.00
Visit (%)	: 50
Max Visits Per Year	: 4
Surgery (%)	: 67
Emergency (%)	: 23
Prescription (%)	: 98
Adult Day Health Care?	: YES
Dental Cov. Type	: PERCENTAGE AMOUNT
Dental Cov. (%)	: 69
Mental Health Inpatient:	
MH Inpt. Max Days/Year	: 89
MH Lifetime Inpt. Max	: 56.32
MH Annual Inpt Max	: 48
Mental Health Inpt. (%)	: 5
Mental Health Outpatient:	
MH Opt. Max Days/Year	: 92
MH Lifetime Opt. Max	: 42
Enter RETURN to continue or '^' to exit:	
MH Annual Opt. Max	: 78
Mental Health Opt. (%)	: 4
Home Health Care:	
Care Level	: THERAPIST/OTHER
Visits Per Year	: 56
Max. Days Per Year	: 89
Med. Equipment (%)	: 50
Visit Definition	: CHECK-UP

```

Hospice:
Annual Deductible      : 10.00
Inpatient Annual Max. : 25.00
Inpatient Lifetime Max. : 100.00
Room and Board (%)    : 30
Other Inpt. Charges (%) : 1

Rehabilitation:
OT Visits/Yr   : 93
PT Visits/Yr   : 99

Enter RETURN to continue or '^' to exit:

ST Visits/Yr   : 92
Med Cnslg Visits/Yr : 94

IV Management:
IV Infusion Opt?      : YES
IV Infusion Inpt?    : YES
IV Antibiotics Opt?  : YES
IV Antibiotics Inpt? : YES

Are you sure you want to edit existing benefit year information for: JAN 1,2001 Y/N?:
YES

```

13. At the Are you sure you want to edit the existing benefit year information for <date> Y/N prompt, enter the YES.

The following screen will display:

```

----- EDIT ANNUAL BENEFITS INFORMATION -----
Benefit Year      : JAN 1,2001//
Policy Information : BLUE CROSS//
Max Out of Pocket : 33.33// 80.00
Ambulance Coverage(%) : 9//

Inpatient:
Annual Deductible : 23//
Per Admis Deduct  : 2// ^

Save Changes to Annual Benefits File Y/N? No//  NO

Do you want to Review the AB Y/N? No//  NO

```

14. At the Save Changes to Annual Benefits File Y/N? prompt, enter NO.

15. At the Do you want to review the AB Y/N prompt, enter N.

16. At the Do you want to Review the CV Y/N? prompt, enter YES.

The following screen will be displayed:

```
Do you want to Review the CV Y/N? No// YES

Coverage Date:
JAN 01, 1995
JAN 01, 2002
APR 08, 2015
APR 10, 2015
APR 20, 2015
APR 25, 2015
SEP 01, 2005
SEP 25, 2005
SEP 22, 2014
SEP 25, 2015
OCT 01, 2003
NOV 01, 2003
DEC 25, 2011
DEC 31, 2015

Enter Existing Date or Add New Coverage Date: JAN 01,1995 (JAN 01, 1995)
```

17. At the Enter Existing Date or Add New Coverage Date prompt, enter the JAN 01, 2001, for this example.

The following screen will be displayed:

```
                                Coverage Limitations Data

INPATIENT:
  Inpatient Coverage           : COVERED
  Inpatient Date of Coverage   : JAN 01, 1995
  Inpatient Limit Comments    : test

OUTPATIENT:
  Outpatient Coverage         :
  Outpatient Date of Coverage :
  Outpatient Limit Comments  :

PHARMACY:
  Pharmacy Coverage          :
  Pharmacy Date of Coverage  :
  Pharmacy Limit Comments   :

DENTAL:
  Dental Coverage            :
  Dental Date of Coverage   :
  Dental Limit Comments     :

Enter RETURN to continue or '^' to exit:

                                Coverage Limitations Data

MENTAL HEALTH:
  MH Health Coverage         :
  MH Health Date of Coverage :
```

```

MH Health Limit Comments      :
LONG TERM CARE:
  Long Term Coverage          :
  Long Term Date of Coverage  :
  Long Term Limit Comments    :

Are you sure you want to Edit existing Coverage Date information: JAN 1,1995 Y/N
?: NO

Do you want to Review the CV Y/N? No//  NO

```

18. At the Are you sure you want to edit existing Coverage Date information Y/N? prompt, enter NO.

19. At the Do you want to Review the CV Y/N prompt, enter N.

The following screen will be displayed:

Policy Data:	Buffer Data	Selected Policy
Company Name:	TEST-1	BLUE CROSS
Group #:	3458	3485
Patient Name:	IBPATIENT, ONE	IBPATIENT,ONE
Last Verified:		APR 23, 2015
Effective Date:	MMM DD, YYYY	JAN 01, 2015
Expiration Date:		JAN 01, 2040
Subscriber Id:		123456789
Whose Insurance:		VETERAN
Relationship:		PATIENT
Rx Relationship:		0
Rx Person Code:		001
Subscriber Name:		IBTEST,EB
Subscriber's DOB:	MMM DD, YYYY	MMM DD, YYYY
Subscriber's SSN:		XX-XX-XXXX
Subscriber's SEX:		FEMALE
Primary Provider:		IBDOCTOR,ONE
Provider Phone:		(555)515-5555
Coor of Benefits:		SECONDARY
Emp Sponsored?:		YES
Patient Id:		7654321
Subscr Str Ln 1:		936 Little Street
Subscr Str Ln 2:		Suite 17
Subscr City:		ANYWHERE
Subscr State:		NEW YORK
Subscr Zip:		11111
Subscr Country:		USA
Subscr Subdiv:		321
Subscr Phone:		(111)111-111
Subscriber Id:	XXXXXXXXXX	XXXXXXXXXX
Enter RETURN to continue:		
Employer Name:		Cognitive Solutions
Emp Status:		
Retirement Date:		
Send to Employer:		
Emp Street Ln 1:		1 Alpha Lane
Emp Street Ln 2:		Galaxy Suite

Emp Street Ln 3:	
Emp City:	ANYTOWN
Emp State:	CALIFORNIA
Emp Zip Code:	99999
Emp Phone:	
	(bold=accepted on merge) (bold=replaced on overwrite)

Is this the correct PATIENT POLICY to match with this Buffer entry? YES

Select the method to update the PATIENT POLICY: (M/O/R/N/I): INDIVIDUALLY ACCEP
T (SKIP BLANKS)

Select the Patient Relationship to Subscriber: 01 SPOUSE

20. At the Is this the correct Patient Policy to match with this Buffer entry? Prompt, enter YES.

21. At the Select the method to update the Patient Policy: (M / O / R / N / I): prompt, enter I.

NOTE: VistA has no control over the information that the payers return, so by selecting **I**, the user has full control over the details that are changed in the VistA insurance file.

The following screen shows the prompts to **Accept, Change, or Replace** entries:

Policy Data:	Buffer Data	Selected Policy
Company Name:	TEST-1	BLUE CROSS
Group #:	3485	3485
Patient Name:	IBPATIENT, ONE	IBPATIENT,ONE
Last Verified:		APR 23, 2015
Effective Date:	MMM DD, YYYY	JAN 01, 2015
Accept Change, Replace? No//	NO	
Expiration Date:		JAN 01, 2040
Subscriber Id:		123456789
Whose Insurance:	VETERAN	VETERAN
Relationship:	PATIENT	PATIENT
Rx Relationship:		0
Rx Person Code:		001
Subscriber Name:		IBTEST,EB
Subscriber's DOB:	MMM DD, YYYY	MMM DD, YYYY
Accept Change, Replace? No//	NO	
Subscriber's SSN:		XX-XX-XXXX
Subscriber's SEX:		FEMALE
Primary Provider:		IBDOCTOR,ONE
Provider Phone:		(555)555-5555
Coor of Benefits:		SECONDARY
Emp Sponsored?:		YES
Patient Id:		XXXXXX
Subscr Str Ln 1:		123 Main Street
Subscr Str Ln 2:		Suite XX
Subscr City:		ANYWHERE

Subscr State:	NEW YORK
Subscr Zip:	11111
Subscr Country:	USA
Subscr Subdiv:	321
Subscr Phone:	(111)111-1111
Subscriber Id: XXXXXXXXXX	XXXXXXXXXX
Accept Change, Replace? No//	NO
Employer Name:	Employer's Name
Emp Status:	
Retirement Date:	
Send to Employer:	
Emp Street Ln 1:	123 Main Street
Emp Street Ln 2:	Galaxy Suite
Emp Street Ln 3:	
Emp City:	ANYTOWN
Emp State:	CALIFORNIA
Emp Zip Code:	99999
Emp Phone:	
	(bold=replaced on overwrite)
	(bold=accepted on merge)

End of changes for POLICY related data.

Enter RETURN to continue or '^' to exit:

Select the Patient Relationship to Subscriber: 01 SPOUSE

22. At the Select the Patient Relationship to Subscriber prompt, enter the 01 SPOUSE for this example.

Subscriber Data:	Patient Registration	Patient Insurance Policy
Subscriber Id:	XXXXXX	XXXXXXXXXX
Whose Insurance:	VETERAN	VETERAN
Relationship:	SELF	SELF
Rx Relationship:	1 - NOT SPECIFIED	0
Rx Person Code:	001	001
Subscriber Name:	IBTEST,EB	IBTEST,EB
Subscriber's DOB:	XXX XX, XXXX	XXX XX, XXXX
Subscriber's SSN:	XX-XX-XXXX	XX-XX-XXXX
Subscriber's SEX:	MALE	MALE
Primary Provider:	IBPROVIDER, ONE	IBPROVIDER, TWO
Provider Phone:	(222)222-2222	(555)555-5555
Coor of Benefits:	PRIMARY	SECONDARY
Patient Id:		2345678
Subscr Str Ln 1:	123 Main Street	123 Main Street
Subscr Str Ln 2:		Suite XX
Subscr City:	ANYWHERE	ANYWHERE
Subscr State:	NEW YORK	NEW YORK
Subscr Zip:	99999	11111
Subscr Country:	USA	USA
Subscr Phone:	777-777-7777	(444)444-4444
	(bold=accepted on merge)	(bold=replaced on overwrite)

Is this the correct SUBSCRIBER INSURANCE to match with this Patient Registration entry? YES

Select the method to update the SUBSCRIBER INSURANCE: (M/O/R/N/I): NO CHANGE

NOTE: Eligibility / benefit data groups may be available on multiple pages. To scroll through each page, enter RETURN. To skip to the last page, enter ^.

23. At the Is this the correct SUBSCRIBER INSURANCE to match with this Patient Registration entry? prompt, enter YES.

24. At the Select the method to update the SUBSCRIBER INSURANCE: (M/O/R/N/I): prompt, enter N.

NOTE: VistA has no control over the information that the payers return, so by selecting **N**, the user has full control over the details that are changed in the VistA insurance file.

```
*** Non-editable Patient Eligibility/Benefit data from payer ***
                Payer Response                VISTA Pt.Insurance
Eligibility Information
Subscriber: IBPATIENT,ONE
Subscriber Id: XXXXXXXXX
Subscriber DOB: XXXXXXXX
Subscriber SSN: XXXXXXXX
Group Name: XXXXXXXX
Group ID: XXXXXXXXXXXXX
Whose Insurance: VETERAN
Pt.Rel. to Subscriber: PATIENT
Member ID:
COB:
Service Date:
Date of Death:
Effective Date: XXX XX, XXXX
Certification Date:
Expiration Date:
Payer Updated Policy:
Response Date: XXX XX, XXXX
Trace #:
Policy Number:

Contact Information                |                Contact Information

Enter RETURN to continue or '^' to exit:
Replace the Pt's Eligibility/Benefits data? YES//
```

25. At the Replace the Pt's Eligibility/Benefits data? prompt, enter YES.

The following screen will be displayed:

```
STEP 1: Insurance Company
There will be NO CHANGE to the existing Insurance Company data.

STEP 2: Group/Plan
There will be NO CHANGE to the existing Group/Plan data.
```

```

STEP 3: Annual Benefits
No Edits made/saved. No data saved into the Annual Benefits File.

STEP 4: Coverage Limitation
No Edits made/saved. No data saved into the Coverage Limitations File.

STEP 5: Patient Policy
The Buffer data will INDIVIDUALLY ACCEPT (SKIP BLANKS) the existing Policy data.

STEP 6: Subscriber Update
There will be NO CHANGE to the existing Patient Insurance data.

STEP 7: Eligibility/Benefits
The Buffer data will replace the existing EB data.

STEP 8: E1 Pharmacy Eligibility
N/A – No E1 Pharmacy Eligibility data

Is this Correct, update the existing Insurance files now? YES ...

Patient Policy Updated...

Warning: Insurance Company selected already on file for this patient.
         The previous entry is active.
         The WHOSE INSURANCE are the same.
         The Group Plans are the same.

Press 'V' to view the changes or Return to continue:

```

26. If you want to review the changes that were made when you chose Individually Accept, at the **Press 'V' to view the changes or Return to continue:** prompt, press **RETURN** for this example.

NOTE: Users may select more than one entry from the buffer at a time to process. The system will then cycle users through each selected entry.

4.2.2 Reject Entry

Users can remove an entry from the Buffer by rejecting the entry.

1. At the **Select Action:** prompt, enter **RE** for Reject Entry.
2. At the **Select Buffer Entry(s): (1-17):** prompt, enter **12** for this example.

The following screen will be displayed:

```

-----
Entered:      9/9/09@13:46                Source:  INTERVIEW
Entered By:  IBclerk,One                  Verified:
Patient:     IBPATIENT,TWELVE            Sub Id:  XXXXXX
Insurance:   IBinsurance Five             Group #:  XXXXX-XX
-----

```

This action will delete all insurance and patient specific data from a buffer entry without first saving that data to the insurance files, leaving a stub entry for reporting purposes.

Reject this buffer entry (delete without saving to Insurance files)? N// Y

3. At the Reject this buffer entry (delete without saving to Insurance files)? N// prompt, enter YES to remove entry from the buffer.

NOTE: Users may select more than one entry from the buffer at a time to reject. The system will then cycle users through each entry prompting them to reject each selected entry.

4.2.3 Expand Entry

Users can **Expand an Entry**. Expanding an entry will cause the following categories of information to be displayed:

- Insurance Company Information
- Group / Plan Information
- Policy / Subscriber Information
- Buffer Entry Information

To Expand an Entry, follow these steps:

1. Access the BI Process Insurance Buffer.
2. At the **Select Action:** prompt, enter **EE** for Expand Entry.
3. At the **Select Buffer Entry(s): (1-17):** prompt, enter **1** for this example and page through the screens.

The following screens will be displayed:

```
Insurance Buffer Entry          Jul 23, 2013@17:16:47          Page: 1 of 4
IBPATIENT,ONE                 XXX-XX-XXXX    DOB: XXX XX, XXXX    AGE: XX
Buffer entry created on 07/05/13 by CLERK,IB (INTERVIEW)

-----

                                Insurance Company Information
Name: XYZ INS                   Reimburse?: WILL REIMBURSE
Phone:                          Billing Phone:
                                Precert Phone:
                                Remote Query From:
Address:

                                Group/Plan Information
Group Plan?: Yes
Group Name: TEST1
Group Number: INS1234
```

```

          BIN:                               Require UR: No
          PCN:                               Require Amb Cert: No
+-----Enter ?? for more actions-----
EI  Ins. Co. Edit      ES  Escalate Entry      EX  Exit
EA  All Edit          PI  Pt. Policy Edit
PE  Group/Plan Edit   EB  Expand Benefits
Select Action: Next Screen//

```

```

Insurance Buffer Entry      Jul 23, 2013@17:19:39      Page: 2 of 4
IBPATIENT,ONE             XXX-XX-XXXX      DOB: XXX XX, XXXX      AGE: XX
Buffer entry created on 07/05/13 by CLERK,IB (INTERVIEW)
-----
Type of Plan:              Require Pre-Cert: No
                          Exclude Pre-Cond: No
                          Benefits Assignable: Yes

                          Policy/Subscriber Information
Whose Insurance: SPOUSE    Effective: 07/01/01
                          Expiration:

Subscriber's Name: IBINS,ACTIVE
Subscriber Id: XXXX
Relationship: SPOUSE      Primary Provider:
                          Provider Phone:
Subscriber's DOB: XX/XX/XX  Coord of Benefits:
                          Patient Id: XXXXXX
-----
+-----Enter ?? for more actions-----
EI  Ins. Co. Edit      ES  Escalate Entry      EX  Exit
EA  All Edit          PI  Pt. Policy Edit
PE  Group/Plan Edit   EB  Expand Benefits
Select Action: Next Screen//      NEXT SCREEN

```

```

Insurance Buffer Entry      Jul 23, 2013@17:20:17      Page: 3 of 4
IBPATIENT,ONE             XXX-XX-XXXX      DOB: XXX XX, XXXX      AGE: XX
Buffer entry created on 07/05/13 by CLERK, IB (INTERVIEW)
-----
Employer Sponsored Group Health Plan?:

                          Buffer Entry Information
Date Entered: 7/5/13@09:05      Date Verified:
Entered By: CLERK,IB           Verified By:
** This response is based on service date XX/XX/XXXX and service type: Health
Benefit Plan Cov **
eIV Trace #: xxxxxxxx         eIV Processed Date: 7/5/13@09:38
Source: INTERVIEW
Current eIV Status: Response Received, Active Policy

Information received via electronic inquiry indicates patient has active
insurance.
-----
+-----Enter ?? for more actions-----
EI  Ins. Co. Edit      ES  Escalate Entry      EX  Exit
EA  All Edit          PI  Pt. Policy Edit
PE  Group/Plan Edit   EB  Expand Benefits
Select Action: Next Screen//      NEXT SCREEN

```

```

Insurance Buffer Entry      Jul 23, 2013@17:20:26      Page: 4 of 4
IBPATIENT,ONE            XXX-XX-XXXX      DOB: XXX XX. XXXX      AGE: XX
Buffer entry created on 07/05/13 by CLERK,IB(INTERVIEW)

+-----
Action to take: Review the details listed in the eIV Response Report
before processing this buffer entry.

-----Enter ?? for more actions-----
EI  Ins. Co. Edit          ES  Escalate Entry          EX  Exit
EA  All Edit              PI  Pt. Policy Edit
PE  Group/Plan Edit       EB  Expand Benefits
Select Action: Quit//

```

Once users access **Expand Entry**, they will have access to the following additional Actions:

- **Ins. Co. Edit** – Allows users to edit or change the Insurance Company.
- **All edit**– Allows users to edit each of the Expand Entry categories.
- **Group/Plan Edit** - Allows users to edit the Group/Plan category.
- **Escalate Entry** – Allows users to escalate an entry, to indicate to other buffer users that the record needs to be processed by someone else with more rights. Only active policies may be ‘Escalated’. Also, not all users may ‘Escalate’ a buffer record. Those users who do not have the IB INSURANCE COMPANY EDIT security key and the IB GROUP PLAN EDIT security key will be the only ones authorized to use this ‘Escalate’ action. These users are restricted to accessing only certain positive “+” buffer entries.
- **Pt. Policy Edit** – Allows users to edit the Policy/Subscriber category.
- **Expand Benefits** – Allows users to see the Eligibility/Benefits data that was returned in the associated 271 Health Care Eligibility Benefits Response if there is one for this entry.

4.2.4 Add Entry

The Add Entry action allows users to manually add a patient to the insurance buffer.

1. At the **Select Action:** prompt, enter **AE** for Add Entry.
2. At the **Select PATIENT NAME:** prompt, enter **IBPATIENT,THIRTEEN** for this example.

The following screen will be displayed:

```
Select PATIENT NAME: IBPATIENT,THIRTEEN X-X-XX   XXXXXXXXX   YES   SC VETERAN
Enrollment Priority:          Category: NOT ENROLLED   End Date:

Financial query queued to be sent to HEC...

      *** Patient Requires a Means Test ***

      Primary Means Test Required from APR 15,1999

Enter <RETURN> to continue.

MEANS TEST REQUIRED
```

3. Follow the prompts shown below to enter the insurance company, group/plan and policy, and subscriber information.
4. When you have added an entry to the insurance buffer, you will be returned to the **Complete Buffer**.

```
Insurance Company: ??

Please enter the name of the insurance company that provides coverage for this
patient. This response is a free text response, however, a partial insurance
company name look-up is available here.

Insurance Company: IBinsurance
  1  IBinsurance One
  2  IBinsurance Two
  3  IBinsurance Three
  4  IBinsurance Four
  5  IBinsurance Five
CHOOSE 1-5: 2

Add a new Insurance Buffer entry for this patient and company? YES//

----- INSURANCE COMPANY INFORMATION -----

INSURANCE COMPANY NAME: IBinsurance Two//
  1  IBinsurance Two
CHOOSE 1-1: 1
REIMBURSE?:
PHONE NUMBER:
BILLING PHONE NUMBER:
PRECERTIFICATION PHONE NUMBER:
STREET ADDRESS [LINE 1]:
CITY:
STATE:
ZIP CODE:

----- GROUP/PLAN INFORMATION -----

The following data defines a specific Group or Plan provided by an Insurance
Company. This may be either a group plan with many potential members or an
individual plan with a single member.
```

IS THIS A GROUP POLICY?: N NO
 GROUP NAME:
 GROUP NUMBER:
 BANKING IDENTIFICATION NUMBER:
 PROCESSOR CONTROL NUMBER (PCN):
 TYPE OF PLAN:
 UTILITIZATION REVIEW REQUIRED:
 PRECERTIFICATION REQUIRED:
 AMBULATORY CARE CERTIFICATION:
 EXCLUDE PREEXISTING CONDITION:
 BENEFITS ASSIGNABLE:

----- POLICY AND SUBSCRIBER INFORMATION -----

The following data defines the subscriber specific policy information for a particular Insurance Plan. The subscriber, the insured, and the policy holder all refer to the person who is a member of the plan and therefore holds the policy. The patient must be covered under the plan but may not be the policy holder.

EFFECTIVE DATE:
 EXPIRATION DATE:
 PT. RELATIONSHIP TO SUBSCRIBER:
 NAME OF SUBSCRIBER:
 SUBSCRIBER'S DOB:
 SUBSCRIBER'S SEX:
 PATIENT PRIMARY ID:
 PRIMARY CARE PROVIDER:
 PRIMARY PROVIDER PHONE:
 COORDINATION OF BENEFITS:
 SOURCE OF INFORMATION: INTERVIEW//
 ESGHP?:
 SUBSCRIBER ADDRESS LINE 1:
 SUBSCRIBER ADDRESS LINE 2:
 SUBSCRIBER ADDRESS CITY:
 SUBSCRIBER ADDRESS STATE:
 SUBSCRIBER ADDRESS ZIP:

4.2.5 Sort Buffer Views

The default sort for all Buffer views (except the **Positive Insurance Buffer**) is alphabetically by patient name. The **Positive Insurance Buffer** is sorted by "+" eIV Status first and then alphabetically by patient name.

Users may re-sort the buffer based upon the following criteria:

- Patient Name
- Insurance Company
- Source of Information
- Date Entered
- Inpatients
- Means Test

- On Hold
- eIV Status
- Positive Response
- Potential new policy

4.2.6 Check Insurance Company

Users may view a list of insurance companies that exist in the insurance buffer that do not match any of the insurance company names or synonyms in the insurance company file. These insurance companies do not match any entries in the IIV AUTO MATCH file.

Once users select the **Check Ins Co's** action, they will have access to the following actions (Refer to Section 7 Auto Match):

- Select Entry
- Auto Match Enter/Edit

To view a list of insurance companies, follow these steps:

1. Access the BI Process Insurance Buffer.
2. At the Select Action: prompt, enter CC for Check Ins Co's.

The following screen will be displayed:

```

Unmatched Buffer Names      Jul 07, 2010@12:02:54      Page: 1 of 1
These are Insurance Company names from the Insurance Buffer file that do not
exist in the Insurance Company file (either as Names or as Synonyms). They
also do not exist or pattern match with any entry in the Auto Match file.

  1  IBinsurance Onee
  2  IBinsurance Twu
  3  IBinsurance Threee

          Enter ?? for more actions
Select Entry      Auto Match Enter/Edit      Exit
Select Action: Next Screen//

```

NOTE: Each buffer entry that fails to make any match to an entry in the Insurance Company file (#36) or the IIV AUTO MATCH file (#365.11) is presented to the user.

This example sets up an auto match entry to associate **IBinsurance Twu** with **IBinsurance Two**.

3. At the **Select Action:** prompt, enter **SE** for Select Entry.
4. At the **Select Entry: (1-192):** prompt select **2** for IBinsurance Twu.

5. At the Select INSURANCE COMPANY NAME: prompt enter IBinsurance Two.

The following screen will be displayed:

Select	INSURANCE COMPANY NAME: IBinsurance Two					
1	IBinsurance Two	SAMPLE RD	MYTOWN	OHIO	Y	
2	IBinsurance Two	TEST RD	MYTOWN	MICHIGAN	Y	
3	IBinsurance Two	PO BOX 5555	ANYTOWN	NEW YORK	Y	
CHOOSE 1-3:	1	IBinsurance Two	SAMPLE RD	MYTOWN	OHIO	Y

6. At the **CHOOSE 1-3:** prompt in this example, enter **1** for **IBinsurance Two SAMPLE RD.**

7. At the Do you want to add an Auto Match entry that associates IBinsurance Twu with IBinsurance Two? No//: prompt, enter YES.

The following prompts are displayed along with a confirmation message:

```
Do you want to add an Auto Match entry that associates
IBinsurance Twu with IBinsurance Two? No// Y YES

AUTO MATCH VALUE: IBinsurance Twu //

IBinsurance Twu is now associated with IBinsurance Two.
```

4.2.7 Buffer Views: Complete, Positive, Negative, Medicare, Failure, ePharmacy

Users may switch back and forth between the different available **Buffer Views** by selecting one of the following actions:

- **PB** – Pos. Buffer
- **NB** – Neg. Buffer
- **MB** – Medicare Buffer
- **FB** – Failure Buffer
- **CB** – Complete Buffer
- **RX** – ePharm Buffer
- **TC** – TRICARE / CHAMPVA

4.2.8 AAA Errors – Complete Buffer View, Expand Entry

Users may view the Error Reporting Codes and corresponding textual descriptions in the Expand Entry when an Error Reporting Code is received in response to an associated 270 Health Care Eligibility Benefits entry.

1. Access the BI Process Insurance Buffer.

2. At the **Select Action:** prompt, enter **EE** to expand an entry that has a "#".

NOTE: Any AAA error messages listed in the Buffer entry.

The AAA errors are displayed as shown in the following sample Expand Entry when accessed from within the Process Insurance Buffer option:

```
Insurance Buffer Entry          May 07, 2013@13:26:09          Page:    4 of    4
IBPATIENT,ONE                XXX-XX-XXXX    DOB: XXX XX,XXXX    AGE: XX
      Buffer entry created on 05/07/13 by IBCLERK,ONE (eIV)

+

Action to take: Review the details listed in the eIV Response Report and
contact the insurance company to manually verify this insurance
information.

                Eligibility Communicator Error Information
Invalid/Missing Subscriber/Insured ID (Error Condition '72')
Please Correct and Resubmit (Error Action 'C')

                Enter ?? for more actions
EI  Ins. Co. Edit          ES  Escalate Entry          EX  Exit
EA  All Edit              PI  Pt. Policy Edit
PE  Group/Plan Edit      EB  Expand Benefits
Select Action: Quit//
```

The AAA errors listed will be identical whether displayed on the Expand Entry screen within the Insurance Buffer or the Response Report called from the eIV **Menu:**

```
eIV Response Report

Insurance verification responses are received daily.
Please select a date range in which responses were received to view the
associated response detail. Otherwise, select a Trace # to view specific
response detail.
      Select one of the following:
          1          Report by Date Range
          2          Report by Trace #
Select the type of report to generate: 1// 2 Report by Trace #
Enter Trace # for report:
Enter Trace # for report: XXXXXXXXXXXXXXXXXXXX    xxxxx,xxxxxx  IBINSURANCE2
      ...OK? Yes// y  (Yes)

DEVICE: HOME//  Linux Telnet/SSH

Compiling report data ...
```

The AAA errors are displayed as shown in the following sample Response Report when accessed from the eIV **Menu**:

```
eIV Response Report by Trace #                               May 07, 2013@11:48:22 Page:1
Trace #: XXXXXXXXXX

Payer: IBINSURANCE2
Patient: IBPATIENT,ONE (SSN: XXX-XX-XXXX DOB: XX/XX/XXXX

Subscriber: IBPATIENT, ONE
Subscriber ID:
Subscriber DOB: XX/XX/XXXX
Subscriber SSN:                               Subscriber Sex: M
Group Name:
Group ID:
Whose Insurance: VETERAN                               PATIENT
Member ID:                               COB:
Service Date:                               Date of Death:
Effective Date:                               Certification Date:
Expiration Date:                               Payer Updated Policy:
Response Date: XX/XX/XXXX                               Trace #: XXXXXXXXXX

ERROR INFORMATION:

Reject Reason Code: 72
Reject Reason Text: Invalid/Missing Subscriber/Insured ID
Action Code: C
Action Code Text: Please Correct and Resubmit
HIPAA Loop: Subscriber Name
HL7 Location: N/A
Error Source: P
```

5 Medicare Potential Insurance Worklist – Potential COB Report

5.1 User Prompts

Users may create a worklist of those patients Medicare has identified in a 271 HL7 response message as having insurance subsequent to their Medicare insurance.

1. Access the Integrated Billing Master Menu.
2. Select the PI Patient Insurance Menu.
3. Select the **EIV eIV MENU**.
4. Select the MW Medicare Potential COB Worklist option.
5. Accept **all default answers** to the prompts for Earliest Report Date, Latest Report Date, and Sort Report By.
6. Select either **S** "Screen List" or **R** "Report" for the format type.

NOTE: This is new for patch IB*2*497.

5.1.1 Search Criteria – Potential COB Worklist

Users may search for patients whom Medicare has identified in a 271 HL7 response message as having insurance subsequent to their Medicare insurance based on the following:

- Earliest Date 271 HL7 message received
- Latest Date 271 HL7 message received

5.1.2 Sort Criteria – Potential COB Worklist

Users may sort entries for patients whom Medicare has identified as having insurance subsequent to their Medicare insurance:

- Chronological Order
- Reverse Chronological Order

5.1.3 Format – Potential COB Worklist

Users may select one of the following formats for the list of patients whom Medicare has identified as having insurance subsequent to their Medicare insurance:

- Report (refer to report section for more details)
- ListManager

5.1.4 Screen ListManager for Completed Entries – Potential COB Worklist

The ListManager view of patients whom Medicare has identified as having insurance subsequent to their Medicare insurance does not display completed entries.

5.1.5 ListManager – Potential COB Worklist

Users may perform the following actions from within the list of patients whom Medicare has identified as having insurance subsequent to their Medicare insurance:

- Mark entry as Not Reviewed
- Mark entry as Review in Process
- Mark entry as Review Complete
- Enter Comments
- View Comments

5.1.6 Comments – Potential COB Worklist

The system captures the following information when users enter comments to an entry on the list of patients whom Medicare has identified as having insurance subsequent to their Medicare Insurance:

- User Name
- Date
- Time

5.1.7 Visual Indicators – Potential COB Worklist

The system provides visual indicators for entries on the list of patients whom Medicare has identified as having insurance subsequent to their Medicare insurance for the following conditions:

- Entries as Not Reviewed
- Entries marked as Review in Process
- Entries marked as Review Complete (can only be seen on the report format)
- Entries the system thinks, based on exact match of insurance company name and address, already exist in the Patient's Insurance

6 Request Electronic Insurance Inquiry

This option allows users to create a Health Care Eligibility Benefits Inquiry whenever needed. In addition, this option also allows a user to create an Electronic Insurance Coverage Discovery (EICD) inquiry when needed.

NOTE: Users must hold the **IBCNE IIV SUPERVISOR** security key to access this option.

6.1 Request a 270 Health Care + Benefits Inquiry

The **Request Electronic Insurance Inquiry** option allows users to create a Health Care Eligibility Benefits Inquiry whenever needed. This option allows users to override the re-verification of Service Date of today and individually select a specific Service Type Code. If no code is selected, the default of Service Type Code as set in the IV Site Parameters is used, typically it is set to 30. Using the default Service Type Code to create a buffer entry allows the entry to auto-update. Selecting any other Service Type code during this process will bypass the auto-update feature, leaving the buffer entry for manual processing.

NOTE: This example will send an insurance inquiry for Service Code Type 87 (cancer). If Service Type Code is defaulted then an inquiry will be sent for the Service Type Code defined in section 2.3 Define Service Code Parameters.

1. Access the PI Patient Insurance Menu.
2. Access the **eIV Menu**.
3. Access the EI Request Electronic Insurance Inquiry option.
4. At the **Select Patient Name** prompt, enter **Patient Name** (in this example IBPATIENT, ONE).

NOTE: Patch IB*2*438 provided the ability to request insurance inquiries with specific Service Type Codes. Patch IB*2*497 removed the ability to request multiple Service Type Codes but does allow for the selection of a single Service Type Code.

The following screen will be displayed:

```
eIV Insurance Request          Dec 22, 2010@16:53:22          Page: 1 of 1
Request Electronic Insurance Inquiry for Patient: IB PATIENT, ONE XXXX

Insurance Co.  Type of Policy  Group      Holder  Effect.  Expires
1  Insurance Comp1          TST1223    OTHER   07/01/2001
2  Insurance Comp2          GRP NUM 20  SELF    04/09/2010

Enter ?? for more actions                                     >>>
SE Select Entry          CD EICD Request
EX Exit
Select Action: Quit// SE  Select Entry
Select entry to request electronic inquiry: (1-2): 1

Enter Service Type Code: 30// ?

Answer with X12 271 SERVICE TYPE CODE
Do you want the entire 187-Entry X12 271 SERVICE TYPE List? N
Enter Service Type Code: 30// ??

Enter the single SERVICE TYPE CODE to be sent with inquiry or press
'ENTER' to send default service type code. The default service type
code may auto-update. All other service types will not auto-update.

Enter Service Type Code: 30// ?

Answer with X12 271 SERVICE TYPE CODE
Do you want the entire 187-Entry X12 271 SERVICE TYPE List? Y (Yes)
Choose from:
1      Medical Care
2      Surgical
3      Consultation
4      Diagnostic X-Ray
5      Diagnostic Lab
6      Radiation Therapy
```

```

7       Anesthesia
8       Surgical Assistance
9       Other Medical
10      Blood Charges
11      Used DME
12      DME Purchase
13      Ambulatory SC Facility
14      Renal Supplies/Home
15      Alt. Method Dialysis
16      CRD Equipment
17      Pre-Admission Testing
18      DME Rental
19      Pneumonia Vaccine
20      2nd Surgical Opinion
'^' TO STOP:

```

Enter Service Type Code: 30// 11 Used DME

For this policy,
the allowable eligibility dates are between 5/13/24 and 12/4/25, inclusive.

Enter Eligibility Date: TODAY//

Are you sure you want to request an insurance inquiry? NO// Y YES

Insurance Buffer entry created!

Enter RETURN to continue or '^' to exit:

5. At the **Select Action** prompt, enter **SE** Select Entry.
6. At the Select entry to request electronic inquiry: (1-2): prompt, enter 1 for this example.
7. At the **SERVICE TYPE CODE** prompt, enter ? for a list of the Service Type Codes or enter the one required. In this example enter **11**. Now select Yes.
8. At the **Enter Eligibility Date** prompt, enter a valid date in **MM/DD/YY**.
9. You will then be prompted Are you sure you want to request an insurance inquiry? Enter Yes for this example. You will see the message Insurance Buffer entry created!

NOTE: An asterisk (*) will indicate that the request already has a matching buffer entry.

6.2 Request an Electronic Insurance Coverage Discovery Inquiry

NOTE: Users must hold the IBCNE EICD REQUEST security key to perform this action.

The **Request Electronic Insurance Inquiry** option also allows a user to create an Electronic Insurance Coverage Discovery (EICD) inquiry when needed. There are

restrictions and this action cannot be used for all patients. This functionality is intended to discover insurance coverage for those veterans who have no active billable insurance on file.

1. Access the PI Patient Insurance Menu.
2. Access the **eIV Menu**.
3. Access the EI Request Electronic Insurance Inquiry option.
4. At the **Select Patient Name** prompt, enter **Patient Name** (in this example IBPATIENT, ONE).
5. At the **Select Action** prompt, enter **CD** EICD Request.
6. You will then be prompted Are you sure you want to request a search for this patient's insurance? Enter YES.
7. The following screen will display with a message stating: An EICD request has been sent. If active insurance is found for this patient results will be displayed in the buffer within 30 days.

```
eIV Insurance Request      Dec 22, 2010@16:53:22      Page: 1 of 1
Request Electronic Insurance Inquiry for Patient: IBPATIENT,ONE  XXXX

Insurance Co.   Type of Policy   Group      Holder   Effect.   Expires

No eligible insurance policies found.

Enter ?? for more actions                                     >>>
SE Select Entry      CD EICD Request
EX Exit
Select Action: Quit// CD   EICD Request
Are you sure you want to request a search for this patient's insurance? YES//

An EICD request has been sent. If active insurance is found for this patient
results will be displayed in the buffer within 30 days.

Type <Enter> to continue or '^' to exit:
```

NOTE: If the patient does not meet the EICD rules, you will see the message: Sorry the patient does not qualify for this action.

7 Patient Insurance Info View / Edit

The Patient Insurance Info View / Edit option is used to look at a patient's insurance information and edit that data, if necessary. The system groups information that is specific to the insurance company, specific to the patient, specific to the group plan, specific to the annual benefits available, and the annual benefits already used.

Once a patient is selected, this screen is displayed listing all the patient's insurance policies. Information provided for each policy may include type of policy, group name, holder, effective date, and expiration date.

7.1 View Patient Policy Information

This screen displays expanded policy information for the selected company. Categories include utilization review data, subscriber data, subscriber's employer information, effective dates, plan coverage limitations, last contact, date of death, and comments on the patient policy or insurance group plan.

1. Access the PI Patient Insurance Menu.
2. Access the PI Patient Insurance Info View/Edit Option.
3. At the Select **Patient Name** prompt, enter **Patient Name**.

The following screen will be displayed:

Patient Insurance Management Jul 21, 2010@13:23:59				Page: 1 of 1	
Insurance Management for Patient: IBPATIENT,ONE XXXXX				XX/XX/XXXX	
1	Insurance Co.	Type of Policy	Group	Holder	Effect. Expires
	IBinsurance	HMO	GRP NUM 13	SELF	08/24/14
Enter ?? for more actions					>>>
AP	Add Policy	EA	Fast Edit All	CP	Change Patient
VP	Policy Edit/View	BU	Benefits Used	WP	Worksheet Print
DP	Delete Policy	VC	Verify Coverage	PC	Print Insurance Cov.
AB	Annual Benefits	RI	Personal Riders	EB	Expand Benefits
RX	RX COB Determination	EI	Request Elec Inquiry	EX	Exit
Select Item(s): Quit//					

4. At the **Select Action** prompt, enter **VP** for Policy Edit/View.

The following series of screens will be displayed:

Patient Insurance Management Jul 21, 2010@13:23:59				Page: 1 of 1	
Insurance Management for Patient: IBPATIENT,ONE XXXX					
1	Insurance Co.	Type of Policy	Group	Holder	Effect. Expires
	IBinsurance	HMO	GRP NUM 13	SELF	06/20/09
Enter ?? for more actions					>>>
AP	Add Policy	EA	Fast Edit All	CP	Change Patient
VP	Policy Edit/View	BU	Benefits Used	WP	Worksheet Print
DP	Delete Policy	VC	Verify Coverage	PC	Print Insurance Cov.
AB	Annual Benefits	RI	Personal Riders	EB	Expand Benefits
RX	RX COB Determination	EI	Request Elec Inquiry	EX	Exit
Select Item(s): Quit// VP Policy Edit/View					

Patient Policy Information Mar 12, 2015@11:15:02 Page: 1 of 8
For: IBPATIENT,ONE XXX-XX-XXXX XX/XX/XXXX
IBinsurance Insurance Company ** Plan Currently Active **

Insurance Company
Company: IBinsurance
Street: XXXXXXXXXXXXX
City/State: XXXXXX, IN 99999
Billing Ph: 800/XXX-XXXX
Fax:
Precert Ph: 800/XXX-XXXX

Precert Portal:

Plan Information
Is Group Plan: YES
Group Name: XXXXXXXX
Group Number: GRP NUM 13
BIN:
PCN:
Type of Plan: HEALTH MAINTENANCE ORGANIZATION
Electronic Type: COMMERCIAL
Plan Filing TF: (2 YEAR(S))
ePharmacy Plan ID:
ePharmacy Plan Name:
ePharmacy Natl Status:
ePharmacy Local Status

Utilization Review Info	Effective Dates & Source
Require UR:	Effective Date: 08/24/14
Require Amb Cert: YES	Expiration Date:
Require Pre-Cert: YES	Source of Info: INTERVIEW
Exclude Pre-Cond:	Stop Policy From Billing: NO
Benefits Assignable: YES	

Subscriber Information
Whose Insurance: VETERAN
Subscriber Name: IBPATIENT,ONE
Relationship: SELF
Primary ID: XXXXXXXXXXXX
Coord. Benefits: PRIMARY

Subscriber's Employer Information	
Employment Status:	Emp Sponsored Plan: No
Employer:	Claims to Employer: No, Send to Insurance
Street:	Retirement Date:
City/State:	
Phone:	

Primary Provider:
Prim Prov Phone:

Subscriber's Information (use Subscriber Update Action)
Subscriber's DOB: XX/XX/XXXX
Str 1: xxxx Test Street
Str 2:
City: ANYWHERE
St/Zip: WY 99999
SubDiv:

Country:
Phone: XXXXXXX
Subscriber's Sex: FEMALE
Subscr's Branch:
Subscr's Rank:

Insurance Company ID Numbers (use Subscriber Update Action)
Subscriber ID: XXXXXXXX

Plan Coverage Limitations

Coverage	Effective Date	Covered?	Limit Comments
INPATIENT	08/24/2014	YES	
OUTPATIENT		BY DEFAULT	
PHARMACY	09/24/2014	NO	
DENTAL		BY DEFAULT	
MENTAL HEALTH		BY DEFAULT	
LONG TERM CARE		BY DEFAULT	
PROSTHETICS		BY DEFAULT	
VISION		BY DEFAULT	

COVERAGE Last Updated 05/02/2023 by LASTNAME,FIRST

User Information

Entered By: IBCLERK,ONE
Entered On: 10/08/14

Last Verified By:

Last Verified On:

Last Updated By: IBCLERK,ONE

Last Updated On: 10/08/14

Comment -- Group Plan

This is a long group comment. This area can hold much more than 80 Characters in the field.

Comment -- Patient Policy

Dt Entered	Entered By	Method	Person Contacted
09/25/15	IBCLERK,TWO	PHONE	USER-A

JUST A COMMENT AND NOTHING ELSE

+09/25/15 IBCLERK,TWO PHONE USER-A

THIS IS A COMMENT THAT IS LONGER THAN 74 CHARACTERS TO SHOW THE WRAP INDICATO

Personal Riders

Rider #1: DENTAL COVERAGE

+ Enter ?? for more actions

PI	Change Plan Info	GC	Group Plan Comments	CP	Change Policy Plan
UI	UR Info	EM	Employer Info	VC	Verify Coverage
ED	Effective Dates	CV	Add/Edit Coverage	AB	Annual Benefits
SU	Subscriber Update	PT	Pt Policy Comments	BU	Benefits Used
IP	Inactivate Plan	EA	Fast Edit All	EB	Expand Benefits
PE	Pharmacy Eligibility	EX	Exit		

Select Action:

7.1.1 Patient Policy Comments

Patch IB*2*528 enhances Patient Policy Comments. The Patient Policy Comments can be accessed from the Patient Policy Information screens. The Patient Policy Comments can now hold 245 characters. This field will also hold a history of previously entered comments. With patch IB*2.0*549, the first 74 characters of the two most recent comments will be displayed when a user selects the action **Policy Edit/View (VP)** from with the Patient Policy Information screens.

1. Access the PI Patient Insurance Menu.
2. Access the PI Patient Insurance Info View/Edit option.
3. At the **Select Patient Name** prompt, enter Patient Name.
4. At the **Select Action** prompt, enter **VP** for Policy Edit/View.

NOTE: A "+" symbol next to a comment indicates that there is more to the comment and only a portion is currently displayed to the user.

The following is a sample of what will be displayed along with other policy related information:

Comment -- Patient Policy			
Dt Entered	Entered By	Method	Person Contacted
09/25/15	IBCLERK,TWO	PHONE	USER-A
JUST A COMMENT AND NOTHING ELSE			
+09/25/15	IBCLERK,TWO	PHONE	USER-A
THIS IS A COMMENT THAT IS LONGER THAN 77 CHARACTERS TO SHOW THE WRAP INDICATO			

To modify, delete, or add a comment, the user must select the **Pt Policy Comments (PT)** action.

5. At the **Select Action** prompt, enter **PT** for Pt Policy Comments.

NOTE: A "+" symbol next to a comment indicates that there is more to the comment and only a portion is currently displayed to the user.

The following screen will be displayed:

Patient Policy Comments	Nov 17, 2015@16:51:41	Page: 1 of 1
Policy Comment History for: IBPATIENT,ONE	XXX-XX-XXXX	XX/XX/XXXX
IBinsurance	** Plan Currently Active **	
Dt Entered	Entered By	Method Person Contacted
1 09/25/15	IBCLERK,TWO	PHONE USER-A
JUST A COMMENT AND NOTHING ELSE		
2 +09/25/15	IBCLERK,TWO	PHONE USER-A
THIS IS A COMMENT THAT IS LONGER THAN 77 CHARACTERS TO TEST THE WRAP INDI		
3 04/26/15	IBCLERK,ONE	MAIL USER-B
Contacted the insurance company to confirm the subscriber ID.		

```

4 +04/26/15 IBCLERK,FOUR PHONE USER-D
CONTACTED THE PATIENT'S GRANDSON WHO WAS ABLE TO CONFIRM THE INSURANCE A
5 +04/25/15 IBCLERK,FOUR PERSONAL USER-B
THIS IS THE VERY FIRST PATIENT POLICY COMMENT FOR IBPATIENT.ONE AND I'M JUST

+ Enter ?? for more actions
EE Expand Entry AC Add Comment SL Search List
EC Edit Comment DC Delete Comment EX Exit
Select Action: Quit//

```

These following actions are available in **Patient Policy Comments** screen:

- **EE** – Expand Entry
- **AC** – Add Comment
- **SL** – Search List
- **EC** – Edit Comment
- **DC** – Delete Comment
- **EX** - Exit

Expand Entry – Use this action to view a specific comment in its entirety including the following additional information that may be associated with that comment:

- Last Edited Date
- Last Edited By
- Contact Person
- Contact Phone #
- Method
- Call Reference #
- Authorization #
- Comment (Entire comment – no truncation)

Add Comment – Use this action to create a new comment. If you were the last person to add a comment and it is the same day as when you added the last comment, this action will function like the “Edit Comment” action.

Search List – Use this action to search all comments for that patient policy. It will display all comments where the search criteria were found in at least one of the following fields:

- Contact Person
- Contact Phone #
- Call Reference #

- Authorization #
- Comment (Entire comment – no truncation)

Edit Comment – Use this action to edit a comment. Comments can be edited later on the same date they were entered. If another comment is entered on that day, the comment will be locked. Users can only edit a comment during the same business day that it was created, until another user creates a new comment. A user cannot edit another user’s comment.

Delete Comment – Use this action to delete a comment. Users who *do not* hold the IBCN PT POLICY COMNT DELETE security key can only delete a comment on the same date it was entered or until another comment is entered on that same day by a different user. After another comment by a different user is entered on the same day or as of the following day, the comment will be locked and cannot be deleted by those users. A user without the IBCN PT POLICY COMNT DELETE key cannot delete another user’s comment. If a user without the security key attempts to delete a comment that is outside those rules, the message “Contact your supervisor for assistance” displays.

Supervisors and managers who hold the IBCN PT POLICY COMNT DELETE security key can delete unwanted comments that are not the latest comment, comments that were not entered on the current date, and comments entered by another user.

Exit – Use this action to leave the Patient Policy Comment screen.

7.2 View Eligibility Benefit Information

This screen allows eligibility / benefit information to be displayed.

1. Access the PI Patient Insurance Menu.
2. Access the PI Patient Insurance Info View/Edit option.
3. At the Select **Patient Name** prompt, enter **Patient Name** (in this example IBPATIENT,ONE).
4. At the Select Action prompt, enter EB for Expand Benefits.

The following screen will be displayed:

```
eIV Elig/Benefit Information Jul 23, 2015@17:41:07 Page: 1 of 11
IBPATIENT,ONE xxx-xx-xxxx IBINSURANCE
** Based on service date 10/17/2024 and service type: Health Benefit Plan Covera
-----
Eligibility/Group Plan Information
-----
Reference ID Qualifier: Plan Number
Reference ID: XXXXXXXXX
Reference ID Qualifier: Group Number
Reference ID: XXXXX
Reference ID description: XXXXX
```

Provider Code: Consulting
Reference ID: XXXX
Provider Code: Admitting
Reference ID: XXXXXXXXXX

Primary Diagnosis Code: 890.1
Diag Code Qualifier: I9C

Summary of eIV Eligibility/Benefit Data

Insurance Type: Preferred Provider Organization (PPO)
Coverage Status: Active Coverage
Plan Date/Effective Date: 11/25/2007

+-----Enter ?? for more actions-----
PS Payer Summary EX Exit
Select Action: Next Screen// NEXT SCREEN

eIV Elig/Benefit Information Jul 23, 2015@17:41:10 Page: 2 of 11
IBPATIENT,ONE xxx-xx-xxxx IBINSURANCE
** This response is based on service date 07/05/2015 and service type: Health
Benefit Plan Cov **

+-----

eIV Eligibility/Benefit Data Group# 1 of 2

Insurance Type: Preferred Provider Organization (PPO)
Elig/Ben Info: Active Coverage
Coverage Level: Individual
Date/Time Qual: Plan D/T Period: 11/25/2007-12/31/9999
Service Type: Health Benefit Plan Coverage
Plan Coverage Desc: STANDARD

eIV Eligibility/Benefit Data Group# 2 of 2

Elig/Ben Info: Deductible
Coverage Level: Individual
Service Type: Health Benefit Plan Coverage
Time Period: Remaining
Plan Coverage Desc: STANDARD
Benefit Amount: 0.00
In-Plan-Network: Not Applicable

+-----Enter ?? for more actions-----
PS Payer Summary EX Exit
Select Action: Next Screen//

- At the **Select Action** prompt, enter **PS for Payer Summary**. (This will show all the other data that the payer responded with, which is not specifically benefit related.)

NOTE: This is the same data that is displayed on the eIV Response Report if one used the trace# to look up the payer's response. The eIV Response Report data is periodically purged from the system; therefore, the data has been added to this screen.

The Eligibility Benefits action (and this subscreen of related information ... Payer Summary) only contains one payer response at any given time.

The following screen will be displayed:

```

eIV Elig/Benefit Information Jul 23, 2015@17:41:07 Page: 1 of 1
IBPATIENT,ONE xxx-xx-xxxx IBINSURANCE
** This response is based on service date 07/05/2015 and service type: Health
Benefit Plan Cov **
-----
Subscriber: IBPATIENT,ONE
Subscriber ID: XXXXXXXXXX
Subscriber DOB: XXXXXXXXXX
Subscriber SSN: XXXXXXXXXXXX Subscriber Sex:
Group Name: XXXXXXXXXXXXXXXX
Group ID: XXXXXXXXXXXXXXXX
Whose Insurance: XXXXXXXX
Patient Relationship to Subscriber: PATIENT
Member ID: XXXXXXXXXXXX
COB: XXXXXXXXXX
Service Date: 07/05/2015 Date of Death:
Effective Date: XXXXXXXXXX Certification Date:
Expiration Date: Payer Updated Policy:
Response Date: XXXXXXXXXX Trace #: XXXXXXXXXXXX
Policy Number: XXXXXXXXXXXX

Contact Information
+-----Enter ?? for more actions-----
EX Exit
Select Action: Next Screen// NEXT SCREEN

```

8 IIV Auto Match Payers

Auto Match is a VistA feature designed to help match user-entered insurance company names to the correct payers in the database. In VistA, there are several places a user can enter an insurance company name (free text) without a list of valid insurance names from which to pick. Patient Registration and the Insurance Buffer are two examples. This can result in misspelled, improperly formatted, or incomplete insurance company names. Auto Match is necessary because the eIV software must be able to identify which insurance company the user is referring to in order to appropriately generate inquiries and process responses. This functionality promotes the use of consistent insurance company names.

There is an IIV AUTO MATCH file (#365.11) in each VistA system. Each record in the file has two fields. The first field, **Entered Name**, stores the insurance company name that the user entered into the VistA system without validation. The second field, **Proper Name**, stores the name of the insurance company that can be found in the INSURANCE COMPANY file (#36) of the VistA database.

The Auto Match feature is used to teach the VistA system how to interpret common misspellings or incomplete entries that users enter when typing in free-text insurance company names.

It is recommended that users run the **Check Ins Co's** action on names from the **Insurance Buffer Views** to initially populate the Auto Match files based on existing entries in the **Insurance Buffer**. Selecting this action will generate a list of insurance company names found in the INSURANCE VERIFICATION PROCESSOR file (#355.33) that do not exist in the INSURANCE COMPANY file (#36). The more one "teaches" the Auto Match functionality, the fewer problems eIV will encounter when it creates insurance inquiries for electronic transmission to the payers.

Users can enter (add), edit, or delete Auto Match entries using the **Menu** option PI > EIV > AE (**Enter/Edit Auto Match Entries**), as described in section [8.3](#).

Users must have the IBCNE EIV IIU MAINTENANCE security key to enter (add), edit, or delete an Auto Match entry.

8.1 Auto Match in VistA Applications

Auto Match is currently used in the **Insurance Buffer**.

When a user types a free-text insurance company name, VistA attempts to match the name with one of the proper insurance company names stored in the INSURANCE COMPANY file (#36). If no match is found, the name as typed by the user is then compared to the list of **Entered Name(s)** in the IIV AUTO MATCH file (#365.11). If there are **Entered Name(s)** in the IIV AUTO MATCH file that match the user-typed name,

they are displayed along with their associated **Proper Name(s)**. Users may then select one of the Proper Names to replace the free-text entry.

Users are not required to accept one of the supplied choices; they can choose to keep the free-text name. The Auto Match process may fail to find matching insurance company name(s), in which case no choices are presented to users.

8.2 Types of Auto Match Matches

8.2.1 Simple Auto Matches

In a simple Auto Match, the **Entered Name** field literally contains the name found in the Insurance Buffer (or entered by a user into the IIV AUTO MATCH file (#365.11)). Leading and trailing spaces are ignored. An entry in the buffer might have **BC/BS** as the **Entered Name** and show **Blue Cross Blue Shield** in the **Proper Name** field. As the insurance staff encounter misnamed insurance companies (i.e., the name on the insurance card does not match the name in the VistA database), users can correct the name and VistA will prompt users to add it as a new record in the IIV AUTO MATCH file (#365.11).

8.2.2 Wildcard Auto Match Matches

In a wildcard Auto Match, simple matches are supported but the wildcard character, the asterisk (*), can also be used. Wildcards may be used to anticipate common spelling mistakes. The asterisk can be substituted for any number of characters. For example, if users enter BC*BS, the system will return all Insurance Company names that begin with BC and end with BS. BC/BS, BC BS, BC-BS, BCBS, and BC / BS would all match BC*BS.

An **Entered Name** may contain more than one asterisk (i.e., BC*BS*). When a wildcard is used, a minimum of four non-wildcard characters must also be specified.

8.3 Enter / Edit Auto Match Entries (AE)

VistA offers a **Menu** option to enter (add), edit, or delete entries in the IIV AUTO MATCH file (#365.11). Each AE option is explained separately below.

8.3.1 Add an Auto Match Entry

1. Access the **eIV Menu**.
2. Select the AE Enter/Edit Auto Match Entries option.

The following prompts display:

```
Select an Auto Match Entry: ??

Choose from:
1199 SEIU           is associated with 1199 NAT'L BEN INPAT
BC/BS OF ILLINOIS  is associated with BCBS WY*
BC/BS OF TEXAS     is associated with BCBS WY*
BCBS                is associated with BCBS WY*

You may enter a new IIV AUTO MATCH, if you wish.
This field is the entered name for the insurance company. This
value holds the 'incorrect' insurance company name which needs
to get corrected and replaced with the valid insurance company
name. Typical values in this field will include common
spelling mistakes and incorrect insurance company names. Also
allowed here is the "*" wildcard character. Any entry with a
wildcard character must also contain at least 4 non-wildcard
characters. Multiple asterisks are allowed here.

Select an Auto Match Entry: TEST ADDED ENTRY

Are you adding 'TEST ADDED ENTRY' as a new IIV AUTO MATCH (the 5TH)? No// Y
IIV AUTO MATCH INSURANCE COMPANY NAME: Z
      1  SAMPLENAME ADMINISTRATORS
CHOOSE 1 - 1: 1
```

3. At the **Select an Auto Match Entry** prompt, type the Entered Name for the entry you want to add (for this example, **TEST ADDED ENTRY**).
4. (For this example) At the Are you adding 'TEST ADDED ENTRY' as a new IIV AUTO MATCH (the 5TH)? No / / prompt, answer YES.
5. At the **IIV AUTO MATCH INSURANCE COMPANY NAME** prompt, enter a valid Proper Name from the Insurance Company file (or enter ??).

NOTE: Remember – the Entered Name must be a minimum of 3 characters. If an '*' is used, it must be accompanied by four additional characters.

Entered Names must be unique. One Entered Name cannot be associated with more than one Insurance Company Name.

8.3.2 Edit an Auto Match Entry

1. Access the **eIV Menu**.
2. Select the AE Enter/Edit Auto Match Entries option.

The following prompts display:

```
Select an Auto Match Entry: ??

Choose from:
1199 SEIU           is associated with 1199 NAT'L BEN INPAT
BC/BS OF ILLINOIS  is associated with BCBS WY*
BC/BS OF TEXAS     is associated with BCBS WY*
```

```

BCBS                is associated with BCBS WY*
TEST ADDED ENTRY   is associated with SAMPLENAME ADMINISTRATORS
You may enter a new IIV AUTO MATCH, if you wish.
This field is the entered name for the insurance company. This
value holds the 'incorrect' insurance company name which needs
to get corrected and replaced with the valid insurance company
name. Typical values in this field will include common
spelling mistakes and incorrect insurance company names. Also
allowed here is the "*" wildcard character. Any entry with a
wildcard character must also contain at least 4 non-wildcard
characters. Multiple asterisks are allowed here.
Select an Auto Match Entry: TEST ADDED ENTRY   is associated with SAMPLENAME
ADMINISTRATORS
    ...OK? Yes//    (Yes)
Do you want to Edit or Delete this entry? E// Edit
AUTO MATCH VALUE:  TEST ADDED ENTRY//
INSURANCE COMPANY NAME: SAMPLENAME ADMINISTRATORS  Replace
    TEST ADDED ENTRY is now associated with SAMPLENAME ADMINISTRATORS.

```

3. At the **Select an Auto Match Entry** prompt, type the Entered Name for the entry you want to edit.
4. At the Do You Want to Edit or Delete this entry? E// prompt, type Edit.
5. At the **AUTO MATCH VALUE** prompt, accept or change the existing Entered Name value.
6. At the **INSURANCE COMPANY NAME** prompt, accept or change Insurance Company to be matched to this entry.

NOTE: Remember – the Entered Name must be a minimum of 3 characters. If an '*' is used, it must be accompanied by four additional characters.

Entered Names must be unique. One Entered Name cannot be associated with more than one Insurance Company Name.

8.3.3 Delete an Auto Match Entry

1. Access the **eIV Menu**.
2. Select the AE Enter/Edit Auto Match Entries option.

The following prompts display:

```

Select an Auto Match Entry: ??

Choose from:
1199 SEIU                is associated with 1199 NAT'L BEN INPAT
BC/BS OF ILLINOIS       is associated with BCBS WY*
BC/BS OF TEXAS          is associated with BCBS WY*
BCBS                     is associated with BCBS WY*
TEST ADDED ENTRY        is associated with SAMPLENAME ADMINISTRATORS

You may enter a new IIV AUTO MATCH, if you wish.

```

This field is the entered name for the insurance company. This value holds the 'incorrect' insurance company name which needs to get corrected and replaced with the valid insurance company name. Typical values in this field will include common spelling mistakes and incorrect insurance company names. Also allowed here is the "*" wildcard character. Any entry with a wildcard character must also contain at least 4 non-wildcard characters. Multiple asterisks are allowed here.

```
Select an Auto Match Entry: TEST ADDED ENTRY      is associated with SAMPLENAME
ADMINISTRATORS
...OK? Yes//      (Yes)
```

```
Do you want to Edit or Delete this entry? E// Delete
Are you sure you want to delete <TEST ENTRY>: ? N//
```

3. At the **Select an Auto Match Entry** prompt, type the Entered Name for the entry you want to delete.
4. At the Do You Want to Edit or Delete this entry? E//, type Delete (Edit is the default).
5. (For this example) At the Are you sure you want to delete <TEST ADDED ENTRY>: ? N// prompt, answer YES.

NOTE: Remember – the Entered Name must be a minimum of 3 characters. If an '*' is used, it must be accompanied by four additional characters.

Entered Names must be unique. One Entered Name cannot be associated with more than one Insurance Company Name.

8.4 Add Auto Match Entries Using Insurance Buffer Data

1. Access the **eIV Menu**.
2. Select the AB Add Auto Match Entries Using Insurance Buffer Data option.

The following prompts display:

```
Unmatched Buffer Names      Jul 07, 2010@12:02:54      Page: 1 of 1
These are Insurance Company names from the Insurance Buffer file that do not
exist in the Insurance Company file (either as Names or as Synonyms). They
also do not exist or pattern match with any entry in the Auto Match file.

  1  IBinsurance Onee
  2  IBinsurance Number Two
  3  IBinsurance Threee

Enter ?? for more actions
Select Entry      Auto Match Enter/Edit      Exit
```

Select an Auto Match Entry: IBinsurance Number Two

Are you adding 'IBinsurance Number Two' as a new IIV AUTO MATCH (the 5TH)? No// Y
IIV AUTO MATCH INSURANCE COMPANY NAME: IBinsurance Two

3. At the **Select Action** prompt, enter **Auto Match Enter/Edit** for this example.
4. Select the AE Enter/Edit Auto Match Entries option.
5. At the Select an Auto Match Entry prompt, enter IBinsurance Number Two for this example.
6. (For this example) At the Are you adding 'IBinsurance Number Two' as a new IIV AUTO MATCH (the 144th)? No// prompt, answer YES.
7. At the IIV AUTO MATCH INSURANCE COMPANY NAME prompt, enter IBinsurance Two for this example.

NOTE: Remember – the Entered Name must be a minimum of 3 characters. If an '*' is used, it must be accompanied by four additional characters.

Entered Names must be unique. One Entered Name cannot be associated with more than one Insurance Company Name.

8.5 Check Insurance Buffer Company Names

As described in section [4.2.6](#), the action **Check Ins Co's** in the **Insurance Buffer** screen is another method of accessing the **Auto Match Enter/Edit** option.

1. Access the PI Patient Insurance Menu.
2. Select the BI Process Insurance Buffer option.

The following screen will be displayed:

Positive Insurance Buffer		May 21, 2010@10:18:01	Page:	1 of	2
Sorted by: Positive Response					
	Patient Name	Insurance Co	Subscr Id	S Entered	iIEYHP
1	+IBPATIENT,ONE	XXXX IBINSURANCE ONE	SUB ID XXXX	E 05/18/10	i
2	+IBPATIENT,TWO	XXXX IBINSURANCE ONEE	SUB ID XXXX	E 05/18/10	i
3	+IBPATIENT,THREE	XXXX IBINSURANCE ONE	SUB ID XXXX	E 05/18/10	i
4	+IBPATIENT,FOUR	XXXX IBINSURANCE TWOO	SUB ID XXXX	P 09/21/04	Y
5	+IBPATIENT,FIVE	XXXX IBINSURANCE FOUR	SUB ID XXXX	P 03/31/05	
6	+IBPATIENT,SIX	XXXX IBINSURANCE FOUR	SUB ID XXXX	P 12/08/04	
7	+IBPATIENT,SEVEN	XXXX IBINSURANCE TWO	SUB ID XXXX	P 11/30/04	Y
8	+IBPATIENT,EIGHT	XXXX IBINSURANCE FOU	SUB ID XXXX	P 02/28/05	YH
9	+IBPATIENT,NINE	XXXX IBINSURANCE ONE	SUB ID XXXX	I 03/29/05	Y
10	+IBPATIENT,TEN	XXXX IBINSURANCE THRE	SUB ID XXXX	I 11/16/04	
11	+IBPATIENT,ELEVEN	XXXX IBINSURANCE TWO	SUB ID XXXX	P 03/31/05	YH
12	+IBPATIENT,TWELVE	XXXX IBINSURANCE FIVE	SUB ID XXXX	I 03/24/05	H

+Active

PE Process Entry	ST Sort List	MB Medicare Buffer	CB Complete Buffer
RE Reject Entry	CC Check Ins Co's	FB Failure Buffer	TC TRICARE/CHAMPVA
EE Expand Entry	PB Pos. Buffer	RX ePharm Buffer	BR Buffer Refresh
AE Add Entry	NB Neg. Buffer	EX Exit	

Select Action: Next Screen//

3. At the Select Action: prompt, enter CC for Check Ins Co's.

The following screen will be displayed:

```

Unmatched Buffer Names      Jul 07, 2010@12:02:54      Page: 1 of 1
These are Insurance Company names from the Insurance Buffer file that do not
exist in the Insurance Company file (either as Names or as Synonyms). They
also do not exist or pattern match with any entry in the Auto Match file.

  1  IBINSURANCE ONEE
  2  IBINSURANCE TWOO
  3  IBINSURANCE FOURX

      Enter ?? for more actions
Select Entry      Auto Match Enter/Edit      Exit
Select Action: Next Screen//

```

8.6 Change Company Name via the Insurance Buffer

Auto Match entries can also be created when users change an **Insurance Buffer** entry's insurance company name in the insurance buffer edit screen. When users change the existing insurance company name, listed on an **Insurance Buffer** entry, VistA prompts users to keep track of the original typed name and new name as an Auto Match entry. If users concur, the original typed insurance company name is treated as the **Entered Name** and the new insurance company name is considered the **Proper Name**. The user is then offered the opportunity to modify the **Entered Name**, possibly to make it more general.

NOTE: This example sets up an auto match entry to associate **IBinsurance Flur** with **IBinsurance Four**.

1. Access the PI Patient Insurance Menu.
2. Select the BI Process Insurance Buffer option.

NOTE: VistA warns users when the **Proper Name** matches an insurance company's name synonym and not the company's name, or the **Proper Name** matches more than one synonym and company name.

The following screen will be displayed:

Positive Insurance Buffer		May 21, 2010@10:18:01	Page:	1 of 1
Sorted by: Positive Response				
	Patient Name	Insurance Co	Subscr Id	S Entered iIEYHP
1	+IBPATIENT,ONE	XXXX IBINSURANCE FOUR	SUB ID XXXX I	07/05/13 Y
2	+IBPATIENT,ELEVEN	XXXX IBINSURANCE TWO	SUB ID XXXX P	03/31/05 YH
3	+IBPATIENT,TWELVE	XXXX IBINSRUANCE FIVE	SUB ID XXXX I	03/24/05 H
+Active				
PE	Process Entry	ST Sort List	MB Medicare Buffer	CB Complete Buffer
RE	Reject Entry	CC Check Ins Co's	FB Failure Buffer	TC TRICARE/CHAMPVA
EE	Expand Entry	PB Pos. Buffer	RX ePharm Buffer	BR Buffer Refresh
AE	Add Entry	NB Neg. Buffer	EX Exit	
Select Action: Exit//				

3. At the **Select Action:** prompt, enter **EE** for **Expand Entry**.
4. At the **Select Buffer Entries:** prompt, enter **6** for this example and page through the screens.

The following screens will be displayed:

Insurance Buffer Entry	Jul 23, 2013@17:16:47	Page:	1 of 4
IBPATIENT,ONE	xxx-xx-xxxx DOB: XXX XX,XXXX	AGE: XX	
Buffer entry created on 07/05/13 by CLERK,IB (INTERVIEW)			

Insurance Company Information			
Name: IBINSURANCE FOUR	Reimburse?: WILL REIMBURSE		
Phone:	Billing Phone:		
	Precert Phone:		
	Remote Query From:		
Address:			
Group/Plan Information			
Group Plan?: Yes			
Group Name: TEST1			
Group Number: IB 1234			
BIN:	Require UR: No		
PCN:	Require Amb Cert: No		
+-----Enter ?? for more actions-----			
EI Ins. Co. Edit	ES Escalate Entry	EX Exit	
EA All Edit	PI Pt. Policy Edit		
PE Group/Plan Edit	EB Expand Benefits		
Select Action: Next Screen//			

Insurance Buffer Entry	Jul 23, 2013@17:19:39	Page:	2 of 4
IBPATIENT,ONE	xxx-xx-xxxx DOB: XXX XX,XXXX	AGE: XX	
Buffer entry created on 07/05/13 by CLERK,IB (INTERVIEW)			

Type of Plan:	Require Pre-Cert: No		
	Exclude Pre-Cond: No		
	Benefits Assignable: Yes		
Policy/Subscriber Information			
Whose Insurance: SPOUSE	Effective: 07/01/01		

```

Subscriber's Name: IBSUBSCRIBER,ONE
Subscriber Id: XXXXXXXXXXXX
Relationship: SPOUSE
Subscriber's DOB: XX/XX/XXXX

Expiration:
Primary Provider:
Provider Phone:
Coord of Benefits:
Patient Id: XXXXXXXXXXXX

+-----Enter ?? for more actions-----
EI  Ins. Co. Edit      ES  Escalate Entry      EX  Exit
EA  All Edit          PI  Pt. Policy Edit
PE  Group/Plan Edit   EB  Expand Benefits
Select Action: Next Screen//  NEXT SCREEN

```

```

Insurance Buffer Entry      Jul 23, 2013@17:20:17      Page: 3 of 4
IBPATIENT,ONE             xxx-xx-xxxx      DOB: XXX XX,XXXX      AGE: XX
Buffer entry created on 07/05/13 by CLERK,IB (INTERVIEW)
+-----
Employer Sponsored Group Health Plan?:

          Buffer Entry Information
Date Entered: 7/5/13@09:05      Date Verified:
Entered By: CLERK,IB           Verified By:
** This response is based on service date 07/05/2013 and service type: Health
Benefit Plan Cov **
eIV Trace #: xxxxxxxx           eIV Processed Date: 7/5/13@09:38
Source: INTERVIEW
Current eIV Status: Problem Identified

Insurance company IBinsurance Flur could not be matched to a valid entry in
the Insurance Company file.

eIV could not create an inquiry for this entry. eIV could not match the
insurance company name in the Insurance Buffer file (#355.33) to a valid
+-----Enter ?? for more actions-----
EI  Ins. Co. Edit      ES  Escalate Entry      EX  Exit
EA  All Edit          PI  Pt. Policy Edit
PE  Group/Plan Edit   EB  Expand Benefits
Select Action: Next Screen//  NEXT SCREEN

```

5. At the **Select Action:** prompt, enter EI for Ins. Co. Edit.
6. At the Insurance Company Name: IBinsurance Flur // prompt, enter IBinsurance Four.
7. At the **CHOOSE 1-5:** prompt, enter **1** for this example.
8. At the Do you want to add an Auto Match entry that associates IBinsurance Flur with IBinsurance Four? No// prompt, enter YES.

The following prompts are displayed along with a confirmation message:

```
----- INSURANCE COMPANY INFORMATION -----  
INSURANCE COMPANY NAME: IBinsurance Flur // IBinsurance Four  
  1  IBinsurance Four  
  2  IBinsurance Four A  
  3  IBinsurance Four B  
  4  IBinsurance Four C  
CHOOSE 1-5: 1  
  
Do you want to add an Auto Match entry that associates  
IBinsurance Flur with IBinsurance Four? No// Y YES  
  
AUTO MATCH VALUE: IBinsurance Flur //  
  
IBinsurance Flur is now associated with IBinsurance Four.
```

9. The user will then be a series of prompts to update the insurance company details. At each prompt, enter **RETURN** to keep the current setting.

```
REIMBURSE?:  
PHONE NUMBER: 8005555555//  
BILLING PHONE NUMBER:  
PRECERTIFICATION PHONE NUMBER:  
STREET ADDRESS [LINE 1]: PO BOX 55555//  
STREET ADDRESS [LINE 2]:  
CITY: ANYCITY//  
STATE: OHIO//  
ZIP CODE: 99999//
```

10. After accepting all the current insurance company settings, the original insurance buffer entry will be displayed showing the revised insurance company.

```
Insurance Entry      Jul 23, 2013@17:16:47      Page:      1 of      4  
IBPATIENT,ONE      xxx-xx-xxxx      DOB: XXX XX,XXXX      AGE: XX  
Buffer entry created on 07/05/13 by CLERK,IB (INTERVIEW)  
  
-----  
  
                          Insurance Company Information  
Name: IBinsurance Four      Reimburse?: WILL REIMBURSE  
Phone:                          Billing Phone:  
                                Precert Phone:  
                                Remote Query From:  
Address:  
  
                          Group/Plan Information  
Group Plan?: Yes  
Group Name: TEST1  
Group Number: IB1234  
BIN:                                Require UR: No  
PCN:                                Require Amb Cert: No
```

```

+-----Enter ?? for more actions-----
EI  Ins. Co. Edit      ES  Escalate Entry      EX  Exit
EA  All Edit          PI  Pt. Policy Edit
PE  Group/Plan Edit   EB  Expand Benefits
Select Action: Next Screen//

```

```

Insurance Buffer Entry      Jul 23, 2013@17:19:39      Page: 2 of 4
IBPATIENT,ONE            xxx-xx-xxxx      DOB: XXX XX,XXXX      AGE: XX
Buffer entry created on 07/05/13 by CLERK,IB (INTERVIEW)
-----
Type of Plan:
                                Require Pre-Cert: No
                                Exclude Pre-Cond: No
                                Benefits Assignable: Yes

                                Policy/Subscriber Information
Whose Insurance: SPOUSE      Effective: 07/01/01
                                Expiration:

Subscriber's Name: IBINS,ACTIVE
Subscriber Id: XXXXXXXXXXXX
Relationship: SPOUSE      Primary Provider:
                                Provider Phone:
Subscriber's DOB: XX/XX/XXXX      Coord of Benefits:
                                Patient Id: XXXXXXXXXXXX

+-----Enter ?? for more actions-----
EI  Ins. Co. Edit      ES  Escalate Entry      EX  Exit
EA  All Edit          PI  Pt. Policy Edit
PE  Group/Plan Edit   EB  Expand Benefits
Select Action: Next Screen//      NEXT SCREEN

```

```

Insurance Buffer Entry      Jul 23, 2013@17:20:17      Page: 3 of 4
IBPATIENT,ONE            xxx-xx-xxxx      DOB: XXX XX,XXXX      AGE: XX
Buffer entry created on 07/05/13 by CLERK,IB (INTERVIEW)
-----
Employer Sponsored Group Health Plan?:

                                Buffer Entry Information
Date Entered: 7/5/13@09:05      Date Verified:
Entered By: CLERK,IB      Verified By:
** This response is based on service date 07/05/2013 and service type: Health
Benefit Plan Cov **
eIV Trace #: xxxxxxxx      eIV Processed Date: 7/5/13@09:38
Source: INTERVIEW
Current eIV Status: Response Received, Active Policy

Information received via electronic inquiry indicates patient has active
insurance.

+-----Enter ?? for more actions-----
EI  Ins. Co. Edit      ES  Escalate Entry      EX  Exit
EA  All Edit          PI  Pt. Policy Edit
PE  Group/Plan Edit   EB  Expand Benefits
Select Action: Next Screen//      NEXT SCREEN

```

```
Insurance Buffer Entry      Jul 23, 2013@17:20:26      Page: 4 of 4
IBPATIENT,ONE             xxx-xx-xxxx      DOB: XXX XX,XXXX      AGE: XX
Buffer entry created on 07/05/13 by CLERK,IB (INTERVIEW)
```

```
+-----+
Action to take: Review the details listed in the eIV Response Report
before processing this buffer entry.
```

```
-----Enter ?? for more actions-----
```

```
EI Ins. Co. Edit      ES Escalate Entry      EX Exit
EA All Edit          PI Pt. Policy Edit
PE Group/Plan Edit   EB Expand Benefits
Select Action: Quit//
```

9 eIV Reports

There are multiple eIV-related reports. An explanation of and instructions for each report are described in this section.

eIV Reports can be found on the **eIV Menu** on the **Patient Insurance Menu**.

```
AB      Add Auto Match Entries Using Insurance Buffer Data
AE      Enter/Edit Auto Match Entries
AR      eIV Ambiguous Policy Report
EI      Request Electronic Insurance Inquiry
HL      HL7 Response Report
IP      eIV Inactive Policy Report
IU      eIV Auto Update Report
MW      Medicare Potential COB Worklist
PR      eIV Payer Report
RR      eIV Response Report
SR      eIV Statistical Report
Select eIV Menu Option:
```

9.1 HL7 Response Report

Purpose of this Report

This report is used to capture incoming and outgoing HL7 messages transmitted from a VistA database to the FSC.

Warning: Only those entries that were once associated with a buffer entry are candidates for this report. Therefore, if the eIV appointment extract verified a policy and the payer response was automatically processed by the software (eIV auto update) then it would never be found on this report, as a buffer entry was not created in that scenario.

Report Parameters

Search Criteria:

- All or Selected Payers
- Response Received Date Range
- All or Selected Patients

Sort Criteria:

- Payer Name
- Patient Name

This is a 132 column report.

Sample Report

HL7 Response Report						Aug 03,
2015@09:12:53 Page: 1						
01/01/2014 - 08/03/2015						
All Payers						
Buffer #	Payer Name	Patient Name	SSN	Dt Sent	Dt Rec'd	Trace #

	CIGNA					Count = 1
	CIGNA	IBTEST,EB	1234		9/24/14@10:10	2424 45

9.2 eIV Auto Update Report

Purpose of this Report

This report is used to view the list of patients whose Patient Insurance Information has been updated automatically based on a 271 Response message.

Report Parameters

Search Criteria:

- Summary or Detailed
- Payer or Source of Information (only applies to 'Summary' version of the report)
- All or Selected Payers (does NOT apply to the 'Source of Information' summary)
- Insurance Company Detail or not (The choice to say do not include details only applies to the 'Payer' summary.)
- All or Selected Insurance Companies (only applies to 'Selected Payers')
- Response Received Date Range (Earliest Date Received defaults to 6 months ago; Latest Date Received defaults to current system date.)
 - User CANNOT run the report for any date prior to 6 months before today's date.
- All or Selected Patients (only applies to the 'Detailed' version of the report)

This is a 132 column report, for the 'Detailed' version of the report.

Sample Report

Auto Update Report		Jun 26, 2023@08:58:26					
Page: 1							
Response Received: 12/28/2022 - 06/26/2023							
Detailed Report: All Payers; All Insurance Companies; All Patients							
Payer	Insurance Co	Patient Name	SSN	Dt Sent	Auto Dt	SOI	eIV Trace#

AETNA	AETNA	Last, First	XXXX	05/25/23	05/25/23@10:42:11	eIV	XXXXXXXXXX
AETNA	AETNA	Last, First	XXXX	05/25/23	05/25/23@10:42:11	eIV	XXXXXXXXXX
AETNA	AETNA	Last, First	XXXX	05/25/23	05/25/23@10:42:11	PreRg	XXXXXXXXXX
BCBS OF COLORADO	BCBS OF WYOMING	Last, First	XXXX	05/25/23	05/25/23@10:42:11	eIV	XXXXXXXXXX
CIGNA	CIGNA	Last, First	XXXX	05/25/23	05/25/23@10:42:11	eIV	XXXXXXXXXX
CIGNA	CIGNA	Last, First	XXXX	05/25/23	05/25/23@10:42:11	eIV	XXXXXXXXXX
CMS	MEDICARE (WNR)	Last, First	XXXX	05/25/23	05/25/23@10:42:11	eIV	XXXXXXXXXX
*****END OF REPORT*****							
Type <Enter> to continue or '^' to exit:							

9.3 eIV Response Report

Purpose of this Report

This report is used to view the data that was received through the eIV process – receipt of 271 Health Care Eligibility Benefits Response messages.

Report Parameters

Search Criteria:

- Response Received Date Range
- Trace #
- All or Selected Payers
- All or Selected Patients
- All Responses or Most Recent (for a payer/patient combination)

Sort Criteria:

- Payer or Patient

Sample Report (Showing the first couple pages of a multipage report)

eIV Response Report

Insurance verification responses are received daily.
Please select a date range in which responses were received to view the associated response detail. Otherwise, select a Trace # to view specific response detail.

Select one of the following:

- 1 Report by Date Range
- 2 Report by Trace #

Select the type of report to generate: 1// Report by Date Range

Start DATE: t-90 (JAN 09, 2025)
End DATE: T (APR 09, 2025)

Payer or <Return> for All Payers:

Patient or <Return> for All Patients: IBPATIENT,ONE

Select one of the following:

- A All Responses
- M Most Recent Responses

Select the type of responses to display: A// Most Recent Responses

Select one of the following:

1 Payer Name
2 Patient Name

Select the primary sort field: 1// Payer Name
DEVICE: HOME//

Compiling report data ...

eIV Response Report Jul 10, 2013@12:08:38 Page: 1
Sorted by: Payer Name Responses Displayed: Most Recent
01/09/2025 - 04/09/2025
All Payers, IBPATIENT,ONE

Payer: AETNA
Patient: IBPATIENT,ONE (SSN: xxx-xx-xxxx DOB: XX/XX/XXXX)

Subscriber: IBINS,ACTIVE
Subscriber ID: XXXXXXX
Subscriber DOB: XX/XX/XXXX Subscriber Sex:
Group Name: TEST1
Group ID: XXXXX
Whose Insurance: OTHER HIPAA Relationship to Sub:
Member ID: COB:
Service Date: Date of Death:
Effective Date: 07/01/2001 Certification Date:
Expiration Date: Payer Updated Policy:
Response Date: 03/07/2025 Trace #: XXXXXXXX
Sub Address:
WILMINGTON
Country: USA
Subdivision: TN

Subscriber Dates:

Discharge: 08/01/2001
Issue: 07/15/2001
COBRA Begin: 05/01/2001
COBRA End: 05/31/2001

Patient Dates:

Plan Begin: 07/01/2001

Eligibility/Group Plan Information

Reference ID Qualifier: OTHER
Reference ID: XXXXXX
Reference ID Qualifier: Group Number
Reference ID: XXXXXXX
Reference ID description: TEST1

Primary Diagnosis Code: 890.1
Diag Code Qualifier: 19C

Summary of eIV Eligibility/Benefit Data

Insurance Type: Medicare Part A
Coverage Status: Active Coverage

9.4 eIV Payer Report

Purpose of this Report

This report is used to monitor the communication between VistA and the payers, including the types of error and warning messages that are received by VistA from the different payers.

Report Parameters

Search Criteria:

- Inquiry Made Date Range
- All or Selected Payers
- Include Rejection Detail (Yes/No)
- All Responses or Most Recent (for a payer/patient combination)

Sort Criteria:

- Payer Name
- Total Inquiries

This is a 132 column report.

Sample Report

eIV Payer Report
Sorted by: Payer

Jun 03, 2010@10:39:21 Page: 1
Rejection Detail: Not Included

05/04/2010 - 06/03/2010
All Payers

Payer [Inactive Date]	Created	Cancel	Queued	***** SENT ***** 1st Att	***** Retry	*** RECEIVED *** Good	*** Error	AvgResp (Days)	Timeout	Pending
IBpayer One	12	0	0	12	0	12	0	0.00	0	0
IBpayer Two	6	0	0	6	1	7	0	0.00	0	0
IBpayer Three	12	0	0	12	0	11	1	0.00	0	0
IBpayer Four	37	0	0	37	3	28	5	0.00	3	5
Grand Totals	67	0	0	67	4	58	6	0.00	3	5

*** END OF REPORT ***

Enter RETURN to continue or '^' to exit:

9.5 Medicare Potential Insurance Worklist - Potential COB Worklist / Report

Purpose of this Report

This report is used to create a list of those patients whom Medicare has identified in a 271 HL7 response message as having insurance subsequent to their Medicare insurance with the following data extracted from the 271 HL7 message when available:

- Patient Name
- Payer Code (primary, secondary, tertiary)
- Name of Insurance Company
- Insurance Company ID
- Review Status (not reviewed, review in process, completed)
- Insurance Company Address
- Insurance Company Phone Number
- Insurance Company Web Address

Report Parameters

Search Criteria:

- Earliest Date 271 HL7 message received
- Latest Date 271 HL7 message received

Sort Criteria

- Chronological Order
- Reverse Chronological Order

Report Format:

- Report
- Screen List (for additional details including screenshot, see in Section 4.3)

Report Type:

- COMPLETED entries ONLY
- COMPLETED entries ONLY with comments
- Exclude COMPLETED entries
- Exclude COMPLETED entries with comments

Sample Medicare COB Report

Pt. Secondary Insurance Report Jul 23, 2013@18:02:01 Page: 1
Sort: Chronological Order 06/23/2013 - 07/23/2013
Includes Completed Entries

IBPATIENT,ONE XX/XX/XXXX 2

IBINSURANCE3 \T\ HEALTH INSURANCE COMPANY, INC.,
2900 NORTH LOOP W
SOMEWHERE, TX XXXXX Phone: 999999999 Website: www. IBinsurance3

IBPATIENT,TWO XX/XX/XXXX 2

HEALTHSPRING LIFE \T\ HEALTH INSURANCE COMPANY, INC.,
2900 NORTH LOOP W
SOMEWHERE, TX XXXXX Phone: 999999999 Website: www. IBinsurance3.com

IBPATIENT,THREE XX/XX/XXXX 2

IBINSURANCE3 \T\ HEALTH INSURANCE COMPANY, INC.,
2900 NORTH LOOP W
SOMEWHERE, TX XXXXX Phone: 999999999
Website: www. IBinsurance3.com

*** END OF REPORT ***

9.5.1 Medicare Potential COB – as a Worklist

User comments are not shown in the Worklist version of the Medicare Potential COB display.

The EE – Expand Entry action is available in **Medicare Potential COB Worklist**.

These following actions are hidden, but available in Medicare Potential COB Worklist:

- + – Next Screen
- - – Previous Screen
- UP – Up a Line
- DN – Down a Line
- > - Shift view to Right
- < - Shift view to Left
- FS – First Screen
- LS – Last Screen
- GO – Go to Page
- RD – Re Display Screen
- PS – Print Screen

- PL – Print List
- SL – Search List
- ADPL – Auto Display (On/Off)
- QU - Quit

Several indicators may be found on the main screen of the worklist:

- Stat – Status of the eIV Response Record. A “Y” means that the review of the response has been started by someone.
- Following the insurance company name:
 - P – the eIV response indicates that the insurance company is the primary insurance
 - S – eIV response indicates that the insurance company is the secondary insurance
 - T – eIV response indicates that the insurance company is the tertiary insurance

Sample Medicare Potential COB Worklist

```

Medicare Potential COB List   Dec 10, 2013@13:47:22           Page:    1 of    1

Sorted in Chronological Order.
---Resp Rcv--Subscriber-----DOB-----Stat-INS COMPANY-----
03/14/13
1          IBPATIENT,ONE   XXXXX 01/01/50   Y    INSURANCE COMPANY ONE (P)
                                         INSURANCE COMPANY TWO

-----*Exact Match-----
EE  Expand Entry
Select Action: Quit// EE
  
```

Once an entry is selected and expanded by using the EE – Expand Entry action, additional actions are available to the user.

Sample Medicare Potential COB Worklist – Expanded Entry

```

Medicare Potential COB List   Jan 06, 2014@07:16:26           Page:    1 of    1

Patient: IBPATIENT,ONE                               In Process
Code  Payer
-----
P    INSURANCE COMPANY ONE

    111 MAIN STREET
    ANYCITY, TX 999991111
    Phone: 1112223333
    Website: www.INSURANCECOMPANYONE.com

    INSURANCE COMPANY TWO

    222 MAIN STREET
  
```

9.6 eIV Statistical Report

Purpose of this Report

This report is used to monitor the eIV and IIU process including statistics based on outgoing inquiries, incoming responses, pending responses and queued inquiries, etc.

This report should be monitored on a daily basis as it provides users the ability to detect eIV and IIU communication problems with the FSC in addition to potential problems in the configuration of the eIV and IIU Site Parameters. It also provides users with a quick view of new eIV and IIU associated payers and a summary of the insurance buffer entries.

This report is distributed daily as a MailMan message to the members of the mail group that is defined in the IB Site Parameters. The MailMan version covers the most recent 24 hours and is based on the default report parameters. The MailMan message is only sent when enabled through the IB Site Parameters.

Report Parameters

- Date Range with Time
- Sections to Display: All, Outgoing Data, Incoming Data, Current Status / Payer Activity

Sample Report

eIV Statistical Report		Jul 19, 2018@14:04:10	Page: 1
Report Timeframe: 07/19/2018 06:00 - 07/19/2018 14:04			
Outgoing Data (Inquiries Sent)	15		
=====			
Insurance Buffer		2	
Appointment		0	
Electronic Insurance Coverage Discovery (EICD)		5	
EICD-Triggered eInsurance Verification		8	
MBI Inquiry		0	
Incoming Data (Responses Received)	15		
=====			
Insurance Buffer		2	
Appointment		0	
Electronic Insurance Coverage Discovery (EICD)		5	
EICD-Triggered eInsurance Verification		8	
MBI Response		0	
Current Status			
=====			
Responses Pending:	0		
Insurance Buffer		0	
Appointment		0	
Electronic Insurance Coverage Discovery (EICD)		0	
EICD-Triggered eInsurance Verification		0	
MBI Inquiry		0	

```

Queued Inquiries:                                0
Insurance Companies w/o National ID:             723
eIV Payers 'Locally Enabled' is NO:            43
IIU Payers 'Receive IIU Data' is NO:           9

```

```

Insurance Buffer Entries:                         450
  User Action Required:                         177
    # of + entries (Payer indicated Active policy) 102
    # of $ entries (Escalated, Active policy)      1
    # of % entries (MBI value received)            0
    # of - entries (Payer indicated Inactive policy) 15
    # of # entries (Policy status undetermined)    33
    # of ! entries (eIV needs user assistance for entry) 14
  Entries Awaiting Processing:                  225
    # of ? entries (eIV is waiting for a response) 0
    # of blank entries (yet to be processed or accepted) 225

```

Payer Activity (During Report Date Range)

=====

New eIV Payers received:

Please link the associated active insurance companies to these payers at your earliest convenience. Locally enable the payers after you link insurance companies to them. For further details regarding this process, please refer to the Electronic Insurance Verification User Guide.

- 1199 NATIONAL BENEFIT FUND
- AARP HEALTH PLAN
- ACORDIA NATIONAL-MOHWK/HCKRY SPRGS
- ACS BENEFIT SERVICES
- WRITERS GUILD

eIV Payers - FSC changed the 'Nationally Enabled' field:

```

1199 NATIONAL BENEFIT FUND      02/13/2015@11:39:40 Set: ON
1199 NATIONAL BENEFIT FUND      02/12/2015@15:25:26 Set: OFF
1199 NATIONAL BENEFIT FUND      02/12/2015@14:56:12 Set: ON
1199 NATIONAL BENEFIT FUND      02/12/2015@14:34:20 Set: OFF

```

eIV Payers - FSC changed the 'Auto Update' field:

No information available

New IIU Payers received:

Please review the payer linking for the associated active insurance companies to these payers at your earliest convenience. To receive incoming IIU records from other VAMCs into your buffer, turn ON the 'Receive IIU Data' field for the payers. For further details regarding this process, please refer to the Electronic Insurance Verification User Guide.

- AETNA
- CIGNA
- CMS

IIU Payers - FSC changed the 'Nationally Enabled' field:

AETNA	06/10/2021@13:20:51 Set: ON
AETNA	06/10/2021@13:19:52 Set: OFF
CIGNA	06/10/2021@13:29:57 Set: OFF

*** END OF REPORT ***

9.7 MailMan Summaries

VistA automatically produces a daily MailMan message with a copy of the eIV Statistical Report summarizing the eIV activity for the preceding 24 hours. This mail message will be sent to those in the pre-determined mail group that is designated in the general parameters section of the **IB Site Parameter**.

Sample - eIV Statistical Report in MailMan Message

```

Subj: ** eIV Statistical Rpt ** [#316226] 06/12/21@07:00 76 lines
From: EIV INTERFACE (IB) In 'IN' basket. Page 1
-----
eIV Statistical Report                               Jun 12, 2021@07:00:07 Page: 1
      Report Timeframe: 06/11/2021 07:00 - 06/12/2021 07:00

Outgoing Data (Inquiries Sent)                      2
=====
  Insurance Buffer                                   2
  Appointment                                       0
  Electronic Insurance Coverage Discovery (EICD)    0
  EICD-Triggered eInsurance Verification           0
  MBI Inquiry                                       0

Incoming Data (Responses Received)                  2
=====
  Insurance Buffer                                   2
  Appointment                                       0
  Electronic Insurance Coverage Discovery (EICD)    0
  EICD-Triggered eInsurance Verification           0
  MBI Response                                     0

Current Status
=====
Responses Pending:                                  0
  Insurance Buffer                                   0
  Appointment                                       0
  Electronic Insurance Coverage Discovery (EICD)    0
  EICD-Triggered eInsurance Verification           0
  MBI Inquiry                                       0

Queued Inquiries:                                   1
Insurance Companies w/o National ID:                 706
eIV Payers 'Locally Enabled' is NO:                 41
IIU Payers 'Receive IIU Data' is NO:                7

Insurance Buffer Entries:                             2
  User Action Required:                             2
    # of + entries (Payer indicated Active policy)  2
    # of $ entries (Escalated, Active policy)       0
    # of % entries (MBI value received)             0
    # of - entries (Payer indicated Inactive policy) 0
    # of # entries (Policy status undetermined)     0

```

```

# of ! entries (eIV needs user assistance for entry)           0
Entries Awaiting Processing:                                   0
# of ? entries (eIV is waiting for a response)                 0
# of blank entries (yet to be processed or accepted)           0

Payer Activity (During Report Date Range)
=====
New eIV Payers received:
-----
No new eIV Payers added

eIV Payers - FSC changed the 'Nationally Enabled' field:
-----
No information available

eIV Payers - FSC changed the 'Auto Update' field:
-----
No information available

New IIU Payers received:
-----
No new IIU Payers added

IIU Payers - FSC changed the 'Nationally Enabled' field:
-----
No information available

*** END OF REPORT ***

```

9.8 MailMan Notification to Link Payers

Vista automatically triggers a mailman message on a weekly basis to the IBCNE EIV Message Mail group if the following information is available:

- Total Number of Nationally Active Unlinked Payers with Potential Matches to active insurance companies.

Sample MailMan Notification

```

Subj: ACTION REQ: POTENTIAL PAYERS TO BE LINKED [#159564] 01/14/11@10:46
7 lines
From: EIV INTERFACE (IB) In 'IN' basket. Page 1 *New*
-----
TOTAL NUMBER OF PAYERS WITH POTENTIAL INSURANCE COMPANY MATCHES: 4
Immediate Attention Required:
-----
Please link the associated active insurance companies to these payers at your
earliest convenience. Please visit the e-Business Projects Webpage on Vista
University Website to download the Link Payer Instructions.
Enter message action (in IN basket): Ignore//

```

9.9 MailMan Notification to Activate Payers

VistA automatically triggers a mailman message on a weekly basis to IBCNE EIV MESSAGE mail group if the following information is available:

- A List of Payers that meet the following criteria:
 - eIV Locally Not Enabled
 - eIV Nationally Enabled

Sample MailMan Notification

```
subj: ACTION REQ: PAYERS TO BE LOCALLY ACTIVATED [#159565] 01/14/11@10:46
12 lines
From: EIV INTERFACE (IB) In 'IN' basket. Page 1 *New*
-----
Nationally Active Payers that are Locally Inactive:
-----
INSURANCE ONE
INSURANCE TWO
INSURANCE THREE

INSURANCE FOUR
INSURANCEFIVE Immediate Attention Required:
-----
Please locally activate the payers after you link insurance companies to them.
Please visit the e-Business Projects Webpage on VistA University Website to
download the Payer Activation Instructions.
Enter message action (in IN basket): Ignore//
```

9.10 eIV Ambiguous Policy Report

Purpose of Report

This report allows users to view ambiguous payer 270 Health Care Eligibility Benefits Responses. Ambiguous payer responses are those responses that do not have enough information for eIV to safely determine if the policy is active or not active.

Report Parameters

Search Criteria:

- Response Received Date Range
- All or Selected Payers
- All or Selected Patients
- All Responses or Most Recent (for a payer/patient combination)

Sort Criteria:

- Payer Name
- Patient Name

Sample Report

eIV Ambiguous Policy Report

Please select a date range in which ambiguous responses were received to view the associated response detail. Date range selection is based on the date that eIV receives the response from the payer.

Start DATE: T-10000 (FEB 22, 1986)
End DATE: T (JUL 10, 2013)

Payer or <Return> for All Payers:

Patient or <Return> for All Patients:

Select one of the following:

A All Responses
M Most Recent Responses

Select the type of responses to display: A// ll Responses

Select one of the following:

1 Payer Name
2 Patient Name

Select the primary sort field: 1// Payer Name
DEVICE: HOME//

Compiling report data ...

eIV Ambiguous Policy Report Jul 10, 2013@12:19:19 Page: 1
Sorted by: Payer Name Responses Displayed: All
02/22/1986 - 07/10/2013
All Payers, All Patients

Payer: IBINSURANCE2
Patient: IB,PATIENT (SSN: xxx-xx-xxxx DOB: XX/XX/XXXX)

Subscriber: IBPATIENT,ONE
Subscriber ID: XXXXXXXXX
Subscriber DOB:
Subscriber SSN: XX-XXX-XXXX Subscriber Sex:
Group Name:
Group ID:
Whose Insurance: VETERAN HIPAA Relationship to Sub:
Member ID: XXXXXXXX COB:
Service Date: Date of Death:
Effective Date: Certification Date:
Expiration Date: Payer Updated Policy:
Response Date: 01/31/2025 Trace #: XXXXXXXX
Sub Address:
OH

9.11 eIV Inactive Policy Report

Purpose of Report

This report displays any inactive insurance policies that the eIV software identified while making 270 Health Care Eligibility Benefits Inquiries.

Users have the ability to define which inactive policies are included in the report based on the reported policy expiration date. This allows users the ability to search for inactive policies that expired within the payer's filing timeframe.

Report Parameters

Search Criteria:

- Response Received Date Range
- All or Selected Payers
- All or Selected Patients
- All Responses or Most Recent (for a payer/patient combination)

Sort Criteria:

- Payer or Patient

Sample Report

eIV Inactive Policy Report

Please select a date range in which inactive responses were received to view the associated response detail. Date range selection is based on the date that eIV receives the response from the payer.

Start DATE: T-10000 (FEB 22, 1986)

End DATE: T (JUL 10, 2013)

Payer or <Return> for All Payers:

Patient or <Return> for All Patients:

Select one of the following:

- A All Responses
- M Most Recent Responses

Select the type of responses to display: A// ll Responses

Select one of the following:

- 1 Payer Name
- 2 Patient Name

Select the primary sort field: 1// Payer Name

DEVICE: HOME//

Compiling report data ...

eIV Inactive Policy Report

Jul 10, 2013@12:23:57 Page: 1

Sorted by: Payer Name

Responses Displayed: All

02/22/1986 - 07/10/2013

All Payers, All Patients

Payer: IBINSURANCE2

Patient: Patient,One (SSN: xxx-xx-xxxx DOB: XX/XX/XXXX)

)

Subscriber: IBPATIENT,ONE

Subscriber ID:

Subscriber DOB:

Subscriber SSN: XXXXXXXXX

Subscriber Sex:

Group Name:

Group ID:

Whose Insurance:

HIPAA Relationship to Sub:

Member ID:

COB:

Service Date:

Date of Death:

Effective Date: 10/01/2010

Certification Date:

Expiration Date:

Payer Updated Policy:

Response Date: 04/24/2024

Trace #: XXXXXX

Sub Address:

OH

*** END OF REPORT ***

10 Exporting Reports to Excel

Users have the ability under most reports to output data in a format that can be opened by Excel.

1. **Run** the report of your choice.
2. At the **format** prompt, choose **Excel**.

A screen similar the following will be displayed:

```
Generate Insurance Company Listings^Nov 19, 2020@08:03:45
List of All Insurance Companies^where NAME Between Aet and Cigna
Active/Inactive^Insurance Name^Reimburse?^Street Address 1^Street Address 2^Stre
et Address 3^City^State^ZIP^Phone Number
Active^BALL AEROSPACE^WILL REIMBURSE^PO BOX 1235^^BROOMFIELD^CO^80038^303/460-2
453
Active^BANKER FIDELITY^WILL REIMBURSE^PO BOX 105652^^^ATLANTA^GA^30348^
Active^BANKERS FIDELITY^WILL REIMBURSE^PO BOX 105652^^^ATLANTA^GA^30348^
```

```

Active^BANKERS LIFE & CASUALTY^WILL REIMBURSE^PO BOX 1935^^^CARMEL^IN^46082-1935
^800 621-3724
Active^BANKERS LIFE & CASUALTY^WILL REIMBURSE^PO BOX 37504^^^OAK PARK^MI^48237-0
504^810/826-4300
Active^BANKERS LIFE & CASUALTY^WILL REIMBURSE^PO BOX 66994^^^CHICAGO^IL^60666-09
94^
Active^BANNER CHOICE PLUS^WILL REIMBURSE^PO BOX 16423^^^MESA^AZ^85211^800 827-24
64 OPT 5
Active^BANNER HEALTH SYSTEMS^WILL REIMBURSE^PO BOX 9239^^^FARGO^ND^58106^
Active^BC/BS RX CARE WYOMING^WILL REIMBURSE^PO BOX 2266^^^CHEYENNE^WY^82003^800
424-7094
Enter RETURN to continue or '^' to exit:

```

3. Capture the output as a text file.

NOTE: The above step will depend on the terminal emulation application being used.

4. Open a blank worksheet in **Excel**, select the **Data** tab, select the **From Text / CSV** button from the Get & Transform Data section. (These instructions vary on Excel version. This is Office 365.)

Figure 4: Open Dialog Box

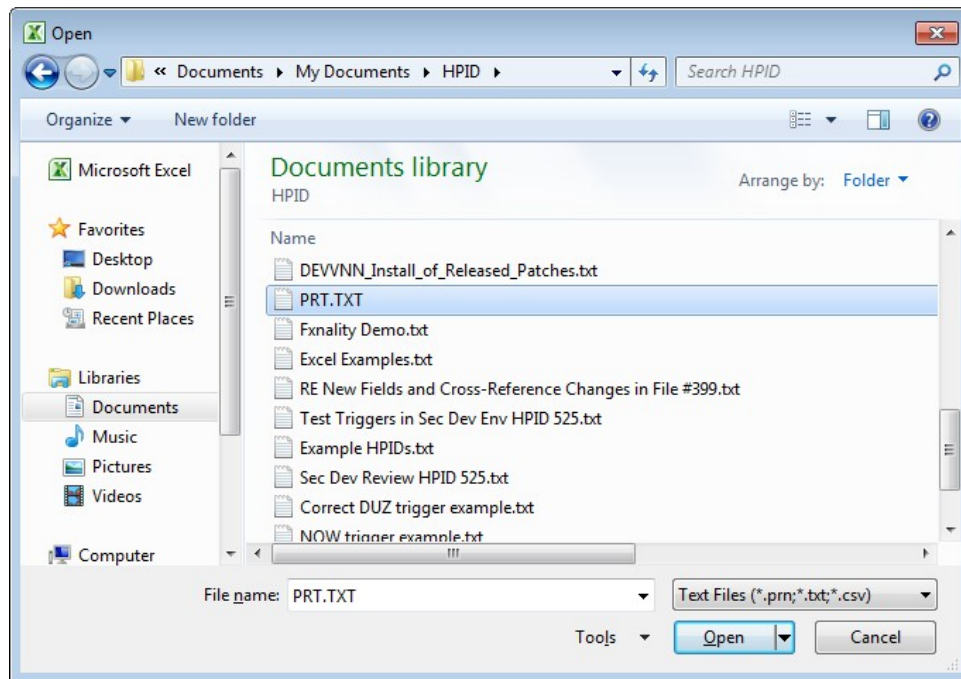

5. **Open** the text file saved in step 3.

The following screen will be displayed.

Figure 5: Opened File

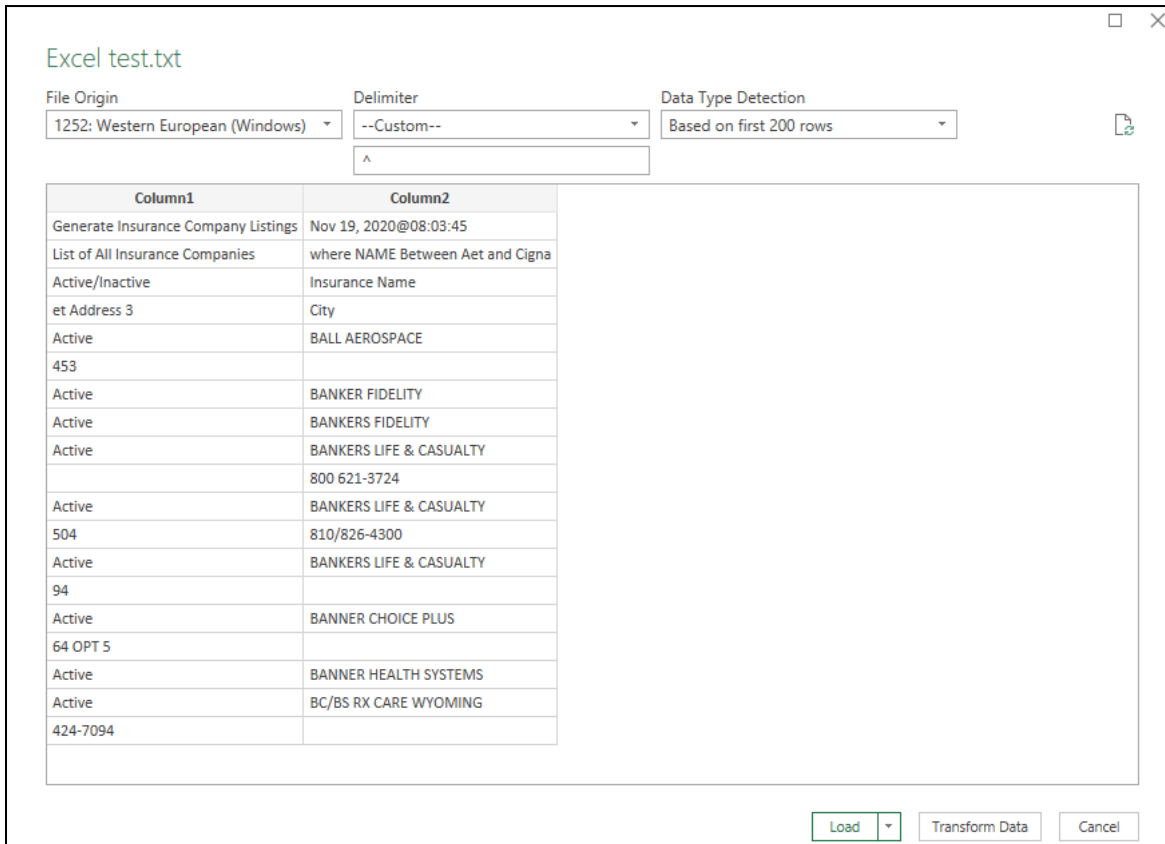

6. Choose **Delimiter**, select **Custom** and enter “^”, and press **Load**.
7. Apply any special formatting.
8. Press the **Finish** button.
9. Depending on your version of Excel, an **Import Data** dialog may display. If it does, select the **New worksheet** and **OK**.
10. **Save** the Excel file.

11 Schedule / Unschedule MailMan Messages

This existing feature allows users to schedule and unscheduled MailMan messages to their preference. Both Activate Payer and Link Payer messages can be scheduled using this option **Unlinked payers notification [IBCNE EIV PAYER LINK NOTIFY]** option.

NOTE: This option is controlled by IRM access only.

The following screens will be displayed:

```
Select OPTION to schedule or reschedule: IBCNE EIV
  1  IBCNE EIV PAYER LINK NOTIFY      Unlinked payers notification

Schedule/Unschedule Options

Select OPTION to schedule or reschedule: unlinked PAYERS NOTIFICATION IBCNE EIV
PAYER LINK NOTIFY      Unlinked payers notification
Are you adding 'IBCNE EIV PAYER LINK NOTIFY' as
a new OPTION SCHEDULING (the 503RD)? No//Y
```

```
Edit Option Schedule
Option Name: IBCNE EIV PAYER LINK NOTIFY
Menu Text: Unlinked payers notification          TASK ID:
_____

QUEUED TO RUN AT WHAT TIME:  MMM DD, YYYY@HH:MM

DEVICE FOR QUEUED JOB OUTPUT:

QUEUED TO RUN ON VOLUME SET:

RESCHEDULING FREQUENCY:    7D

TASK PARAMETERS:

SPECIAL QUEUEING: < This field is only for special jobs:
1. That need to start every time the system is rebooted.
2. Need to be persistent.
3. BOTH >

MAIL CODE:
```

12 Real Time Insurance Verification Inquiry

A real time eligibility verification inquiry is created when a new buffer entry has been entered in the INSURANCE VERIFICATION PROCESSOR file #355.33 (buffer). The inquiry is triggered immediately if the following information is available in the buffer entry:

- INSURANCE COMPANY NAME,
- PATIENT NAME,
- SUBSCRIBER ID (if patient is the subscriber),
- INSURED'S DOB (if patient is not the subscriber), and
- PATIENT ID (if patient is not the subscriber)

No inquiry will be created if:

- An inquiry already exists in the queue waiting to be transmitted.
- The same patient and policy are waiting for a response from the payer.
- The patient insurance information is locked by another user.
- The 270 Master Switch Realtime field (#350.9, 51.27) is set to NO.
 - Displayed as "Master Switch Realtime" under the eIV site parameters.

Real time inquiry is triggered by modifications to the following fields in the buffer:

- INSURANCE COMPANY NAME; or
- GROUP NAME; or
- GROUP NUMBER; or
- PATIENT NAME; or
- SUBSCRIBER ID; or
- INSURED'S DOB; or
- PATIENT ID

NOTE: Remember – To utilize the benefit of real-time verification and get immediate responses, the facility should set the "HL7 Response Processing Method" to "Immediate".

Remember – The Request Electronic Inquiry option can be used to create a buffer entry for real-time verification. The response received for buffer entries created by EI; stay in the buffer and never automatically updates the patient insurance file.

Remember – Real time verification inquiries are not triggered for buffer entries created by HMS data upload. Source = HMS.

Remember – The system does not send a registration request message to FSC each time a real time insurance verification is triggered.

Remember – If the 270 Master Switch Realtime is set to NO, then the inquiry will be added to the buffer but will not transmit to the payer until the eInsurance Night Process runs. The eInsurance Night Process will not run if the 270 Master Switch Nightly field (#350.9, 51.28) is set to NO. (Displayed as "Master Switch Nightly" under the eIV site parameters.)

13 Purging eIV Files (IRM Users)

13.1 Purge Transmission Queue and or Response File

IRM users have the ability to purge files from the IIV TRANSMISSION QUEUE file (#365.1) and IIV RESPONSE file (#365) beyond a date range. The **Purge eIV Transactions** option is on the **Purge Menu** which is on the **System Manager's Integrated Billing Menu**.

1. Access the IRM System Manager's Integrated Billing Menu.
2. Access the **Purge Menu**.
3. Access the Purge eIV Transactions option.

NOTE: Purged data can fill journal files if the files are not purged routinely. It may be a good idea to temporarily disable journaling of the global that includes the IIV TRANSMISSION QUEUE (#365.1) and IIV RESPONSE (#365) files prior to running the purge if the files have not been purged in a long time.

The Purge eIV Transactions option is locked with the **XUMGR** security key.

The following screen will be displayed:

```
Purge Electronic Insurance Identification and Verification (IIV) Data Files

This option will allow you to purge data from the IIV Response File (#365)
and the IIV Transmission Queue File (#365.1). The data must be at least six
months old before it can be purged. Only insurance transactions that have a
transmission status of "Response Received", "Communication Failure", or
"Cancelled" may be purged. You will be allowed to select a date range for
this purging. The default beginning date will be the date of the oldest
eligible record in the system. The default ending date will be six months
ago from today's date. You may modify this default date range. However, you
may not select an ending date that is more recent than six months ago.

Enter the purge begin date: 10/04/2004// 3/8/09 (MAR 8, 2009)

Enter the purge end date: 04/08/2009// (APR 08, 2009)

You want to purge all IIV data created between 03/08/2004 and 04/08/2009.

OK to continue? N0//
```

4. At the **Enter the Purge Begin Date:** prompt, enter 6 Months plus 30 days for this example.
5. At the **Enter the Purge End Date:** prompt, press **RETURN** to accept the default.
6. At the **OK to continue:** prompt, enter **YES**.

NOTE: Files that are not older than six months cannot be purged.

13.2 Purge Mailman Reminder

On the first day of each month, during the nightly batch extract process, the eIV application determines if historical data exists that is eligible to be purged. The process utilizes the same search criteria used by the **Purge eIV Transactions** utility described above. If at least one eligible eIV transaction exists, the mail group defined in the **General Parameters** section of the **IB Site Parameters** will receive the following MailMan reminder.

```
Subj: eIV Data Eligible for Purge [#13511224] 11/06/03@17:37 13 lines
From: IB IIV INTERFACE In 'IN' basket. Page 1
Subject: eIV Data Eligible for Purge
```

ATTENTION IRM: There are eIV TRANSMISSION QUEUE and eIV RESPONSE records eligible to be purged.

File	Eligible Count	Total Count
-----	-----	-----
IIV RESPONSE FILE (#365)	267	1993
IIV TRANSMISSION QUEUE FILE (#365.1)	331	2400
=====	=====	=====
Total	598	4393

Please run option IBCNE PURGE IIV DATA - Purge eIV Transactions, if you would like to purge the eligible records.

14 Appendix A – eIV Troubleshooting

14.1 No eIV Inquiries Transmitted

If the **Inquiries Sent** and **Responses Received** entries on the **eIV Statistical Report** both remain at zero while the **Queued Inquiries** entry on the report continues to increase over a period of time, then no 270 Health Care Eligibility Benefits Inquiry transmissions are being sent to FSC. If this situation continues and both the **Inquiries Sent** and **Responses Received** entries remain at zero, there is a communications problem with FSC. This section provides information to restore connectivity to FSC.

The eIV Statistical report should be reviewed the following day to ensure that 270 Health Care Eligibility Benefits Inquiry transmissions are once again being sent to FSC.

14.1.1 Site Parameters

- Verify MCCR Site Parameters
 - Check Insurance Verification site parameters (IV) >> General Parameters (non-editable)
 - Mail Group must be: IBCNE EIV MESSAGE
 - IBCNE EIV MESSAGE mail group must be populated with valid personnel

14.1.2 Restoring Connectivity to FSC (IRM)

- Verify that the names of the HL7 Logical Links were not changed. It must be **IIV EC**.
- Verify the following settings for the HL7 Logical Link **IIV EC**.
 - The institution field is **blank**.
 - The AUTOSTART field is set to **enabled**.
 - For help with the settings for the following fields, please contact the eInsurance Rapid Response team.
 - The domain field
 - The TCP / IP address
 - The TCP / IP port
- Verify that the HL7 Logical Link IIV EC is running.
- Ask the IB Supervisor or insurance personnel to review the **eIV Statistical Report** the following day and confirm that connectivity has been restored with FSC.

- If this does not resolve the connectivity issue with FSC for eIV, ask the IB Supervisor or insurance personnel to log a Remedy Ticket with VA Product Support.

14.1.3 Requeue Batch Process (IRM)

- Verify the eInsurance Night Process [IBCN EINSURANCE NIGHT PROCESS] is still a scheduled option in Taskman.
 - Reschedule the [IBCN EINSURANCE NIGHT PROCESS] task matching the settings (frequency, date / time to run) of another VAMC production site.

14.1.4 Restart HL7 Logical Link (IRM)

- **Verify** the "IIV EC" HL7 logical link is running.
- **Stop & Restart** "IIV EC" HL7 logical link.

14.2 No link between an Insurance Company and a Payer

For eIV to work, insurance companies must be linked to a payer. This is an important on-going process. To link insurance companies to a payer, follow the basic guidelines listed below:

- Identify insurance companies not linked to a payer by running the following report:
 - Run the **Insurance Company Link Report** for all ***unlinked*** insurance companies.
 - Use the keyword feature or select company feature when running the report to narrow down the search.
- Link the insurance companies to a payer:
 - Use the **Insurance Company Entry/Edit** option to link the identified insurance companies to the correct payer.

14.3 A Buffer or Appointment Extract Entry Failed to Create an Inquiry

When the eIV process is unable to create and transmit a 270 Health Care Eligibility Benefits Inquiry to a payer, the entry in **Process Insurance Buffer** will be flagged with an exclamation point. To view the error or problem that eIV encountered, expand the buffer entry using the **Expand Entry** action. Underneath the section **Buffer Entry Information**, the error message will be displayed as the **Current eIV Status**. Read the explanation of the problem. Sometimes there is more than one way to correct the

problem. For a possible solution, follow the instructions listed below for the specific error. These instructions usually start with, **Action to take**.

For a list of all Error Messages that may display as the **Current eIV Status** of an insurance buffer entry, see [Appendix B – eIV Error Message Descriptions](#).

15 Appendix B – eIV Error Message Descriptions

1. **eIV could not create an inquiry for this entry.** eIV could not match the insurance company name in the Insurance Buffer file (#355.33) to a valid insurance company name in the Insurance Company file (#36).

Action to take: Correct the spelling of the insurance company name found in the buffer so that it matches one found in the Insurance Company file (#36). Otherwise, contact the insurance company to manually verify this insurance information.

2. **eIV could not create an inquiry for this entry.** eIV matched the insurance company name in the Insurance Buffer file (#355.33) to more than one uniquely named insurance company in the Insurance Company file (#36). This indicates that the Auto Match check or the Synonym check yielded multiple insurance companies from the Insurance Company file.

Action to take: Correct the spelling of the insurance company name found in the buffer so that it matches one found in the Insurance Company file (#36). Otherwise, contact the insurance company to manually verify this insurance information. (* Advanced users: Use the option “**Enter/Edit Auto Match Entries**” to check the entries in the Auto Match file (#365.11). Make sure there is no more than one entry in the Auto Match file, if any, which corresponds to the insurance company name found in this buffer entry.)

3. **eIV could not create an inquiry for this entry.** eIV matched the insurance company name in the Insurance Buffer file (#355.33) to more than one insurance company entry with the same name in the Insurance Company file (#36). At least one of these matching entries are linked to a different payer.

Action to take: Run the “**Ins Company Link Report**” option for all linked insurance companies, using the keyword feature to narrow down the search. This will provide a report showing which payer the different insurance company records are linked to. Next, use the “**Insurance Company Entry/Edit**” option to correct those insurance companies who are linked to the wrong payer.

4. **eIV could not create an inquiry for this entry.** There is no link for this insurance company between the Insurance Company file (#36) and the Payer file (#365.12). This may occur because the insurance staff did not attempt to manually link the named insurance company to the payer list or the insurance staff did not find a payer in the payer list that they wanted to link this insurance company to.

Action to take: Either contact the insurance company to manually verify this insurance information or link the insurance company to a payer. Steps to link an insurance company to a payer are as follows: run the “**Ins Company Link**

Report” option for all unlinked insurance companies. Use the keyword feature or select the specific company when running the report to narrow down the search. This will provide a report showing which insurance companies are not linked to a payer. Next, use the **“Insurance Company Entry/Edit”** option to link those insurance companies to the correct payer.

5. **eIV could not create an inquiry for this entry.** The payer is not nationally enabled for eIV.

Action to take: Contact the insurance company to manually verify this insurance information.

6. eIV could not create an inquiry for this entry. The payer is not locally enabled for eIV.

Action to take: Either use the option **“Payer Edit”** to locally enable this payer or contact the insurance company to manually verify this insurance information.

7. **eIV could not create an inquiry for this entry.** The payer does not accept electronic insurance eligibility requests. The eIV application data does not exist in the Payer file (#365.12) for this payer.

Action to take: Contact the insurance company to manually verify this insurance information.

8. Information received via electronic inquiry indicates patient has active insurance.

Action to take: Review the details listed in the **eIV Response Report** before processing this buffer entry.

9. Information received via electronic inquiry indicates patient does NOT have active insurance.

Action to take: Review the details listed in the **eIV Response Report** before processing this buffer entry.

10. **This buffer entry is currently still being processed by the eIV application.** Unless instructed otherwise, there is no reason you should do anything with this buffer entry.

Action to take: None.

11. The electronic response indicated an error of some kind that needs to be corrected before the insurance inquiry can be re-transmitted.

Action to take: Contact the insurance company to manually verify this insurance information.

12. An unknown and unforeseen error has occurred with this entry.

Action to take: Please call the Help Desk for this issue; include a trace number if available.

13. **eIV could not create an inquiry for this entry.** The insurance company found is listed as inactive in the Insurance Company file (#36).

Action to take: Contact the insurance company to manually verify this insurance information.

14. eIV could not create an inquiry for this entry. eIV cannot send inquiries to Medicaid.

Action to take: Contact the insurance company to manually verify this insurance information.

15. eIV was unable to electronically verify this insurance information due to a communication failure.

Action to take: Contact the insurance company to manually verify this insurance information.

16. The insurance company name for this buffer entry is blank.

Action to take: Please call the Help Desk and provide them with buffer information and trace number, if available.

17. **eIV could not create an inquiry for this entry.** The payer associated with this insurance company has been deactivated.

Action to take: Either edit this insurance company and link it to another payer, using the "**Insurance Company Entry/Edit**" option; otherwise, contact the insurance company to manually verify this insurance information.

18. **eIV could not create an inquiry for this entry.** This inquiry requires the Subscriber ID field to be populated before an inquiry can be transmitted electronically.

Action to take: Update the inquiry with the missing Subscriber ID or contact the insurance company to manually verify this insurance information.

19. **An ambiguous response has been received.** It could NOT be determined whether the insurance company identified the patient as an active member of the insurance plan. Please contact the insurance company to manually verify this insurance information.

Action to take: Review the details listed in the **eIV Response Report** and contact the insurance company to manually verify this insurance information.

20. While processing a payer response, an unknown and unforeseen error has occurred with this entry.

Action to take: Please call the Help Desk for this issue; include a trace number if available. A user may process this buffer entry if a Help Desk call has been logged with the associated trace number. To process this buffer entry, review the details listed in the **eIV Response Report** and contact the insurance company to manually verify this insurance information.

21. **eIV could not create an inquiry for this entry.** This dependent inquiry requires the Patient ID field to be populated before an inquiry can be transmitted electronically.

Action to take: Update the inquiry with the missing Patient ID or contact the insurance company to manually verify this insurance information.

22. eIV was unable to electronically verify this insurance information due to a communication failure.

Action to take: Contact the insurance company to manually verify this insurance information.

23. Information received via electronic inquiry indicates patient has active insurance; however, another verifier did not have the authority to process this entry.

Action to take: Review the details listed in the **eIV Response Report** before processing this buffer entry.

24. eIV was unable to electronically verify this insurance information as invalid characters were identified in a required field(s).

Action to take: Contact the insurance company to manually verify this insurance information.

NOTE: Error messages 26 and 27 intentionally omitted.

16 Appendix C – Acronyms / Abbreviations / Terms

Table 14: Acronyms / Abbreviations / Terms

Term	Definition
AITC	Austin Information Technology Center.
EC	Eligibility Communicator – this refers to the National Health Insurance database that is housed at the FSC. The eIV software communicates with the Eligibility Communicator directly through HL7.
EDI	Electronic Data Interchange.
EICD	Electronic Insurance Coverage Discovery.
eIV	Electronic Insurance Verification. It is also the Insurance buffer entry source name in the Insurance Buffer List to signal entry processing by Electronic Insurance Verification.
Freshness Days	FRESHNESS DAYS (#350.9,51.01) is a general site parameter that determines how recent the insurance verification must be before eIV seeks to electronically re-verify it.
FSC	VA Financial Services Center – Austin, TX.
HL7	Health Level Seven, a standardized application level communications protocol that enables systems to exchange information.
HMO	Health Maintenance Organization.
HPID	Health Plan Identifier.
IIU	Interfacility Insurance Update. This term refers to the automated push of active, verified insurance information in real time from the VistA instance used to verify to the account, to other VistA instances where the Veteran has received care.
IIV	Insurance Identification and Verification. This nomenclature was used during initial software development. The official title of the software is now eIV, although some programming options are still labeled with the old IIV nomenclature.
Insurance Buffer	The data store within the VistA database that holds proposed permanent insurance file changes for review and acceptance and upon acceptance, merges the changes into the permanent insurance files. The IBCN Insurance Buffer Process option available in VistA is also known as Process Insurance Buffer.
IRM	Information Resource Management.

Term	Definition
MailMan	MailMan is an integrated data channel in VistA for the distribution of: Patches (KIDS builds), software releases (KIDS builds), computer-to-computer communications (HL7 transfers, Servers, etc.), Person-to-person messaging (Email).
MCCF	Medical Care Cost Fund.
MCCR	Medical Care Cost Recovery. This term has been officially replaced by MCCF though both are used interchangeably.
OEID	Other Entity Identifier.
Payer	An entity that makes third party payments (the patient is the first party, VHA is the second party) for health care services. Health care insurance companies are payers.
Provider	A term used to describe both human and organizational entities that provide health care.
SRS	Software Requirements Specification.
Trusted Payer	A payer whose responses, the FSC determines can be used for Automatic Updates. It is also referred to as the Automatic Update Setting.
VA	Veterans Administration.
VAMC	Veterans Administration Medical Center.
VHA	Veterans Health Administration.
VISN	Veterans Integrated Service Network.
VistA	Veterans Health Information Systems & Technology Architecture, which includes the systems formerly known as the Decentralized Hospital Computer Program (DHCP) System.
WNR	Will not reimburse.
X12	A standardized application level communications protocol that enables systems to exchange information.

17 APPENDIX D – Revision History Archive

The [Abbreviated Revision History](#) at the beginning of the document includes only the most recent updates. For brevity, the “Revision History” is truncated. The complete list of prior revisions is archived in Table 15.

Table 15: Revision History Archive

Date	Revision	Description	Author
08/2022	3.6	Updated IB*2*713 <ul style="list-style-type: none"> • Update to IV Site Parameters screen 	MCCF EDI TAS eInsurance
05/2022	3.5	Updated IB*2*702 <ul style="list-style-type: none"> • Update to Request Electronic Insurance Inquiry • Update to IV Site Parameters screen • Update to eIV Reports screen, • Update to eIV Response Report screen • Update to eIV Ambiguous Policy Report • Update to eIV Inactive Policy Report 	MCCF EDI TAS eInsurance
12/2021	3.4	Updated IB*2*687 <ul style="list-style-type: none"> • Update to Site Parameters • Update to eIV Statistical Report • Update to Payer Edit • Update to Link Insurance Company to Payers using Insurance Company Editor • Removed eIV Payer Link Report which is now in the IB User Manual 	MCCF EDI TAS eInsurance
04/2021	3.3	Updated IB*2*668 <ul style="list-style-type: none"> • IIU: Remove all old SSVI files routines and components • New Source of Information • Updated section 11 • Update to PAL template v1.8, July 2016 	MCCF EDI TAS eInsurance
11/2020	3.2	Updated IB*2*664 <ul style="list-style-type: none"> • Updated User Edit Report 	MCCF EDI TAS eInsurance

Date	Revision	Description	Author
04/2020	3.1	Updated IB*2*659 <ul style="list-style-type: none"> Updated section 2 Site Parameters to bring it up to date and add the new functionality from IB*2*659 	REDACTED
12/2019	3.0	Updated IB*2*652	REDACTED
10/2019	2.9	Updated IB*2*631	REDACTED
01/2019	2.8	Updated IB*2*621	REDACTED
06/2018	2.7	Updated IB*2*595	REDACTED
03/2018	2.6	Updated IB*2*601	REDACTED
06/2017	2.5	Updated IB*2*582	REDACTED
08/2016	2.4	Updated IB*2*549	FY15 eInsurance Development Team
02/2016	2.3	Updated IB*2*525, IB*528	Harris Team
1/2/2015	2.2	Updated IB*2*521 (Payer Link Report)	FirstView Team
5/22/2014	2.1	Updated IB*2*111	FirstView Team
1/29/2014	2.0	Updated IB*2*497	FirstView Team
12/20/2011	1.7	Tech Writer Review	REDACTED
11/17/2011	1.6	Updated IB*2*467	REDACTED
8/02/2011	1.5	Updated IB*2*438	REDACTED
9/24/2010	1.4	Updated IB*2*416	REDACTED
7/28/2005	1.2	Updated IB*2*300	REDACTED
5/06/2005	1.3	Updated IB*2*316	REDACTED
2/08/2005	1.1	Updated IB*2*271	REDACTED
9/18/2003	1.0	IB*2*184	REDACTED